



IMPROVEMENTS TO TRANSMISSION EXPANSION PLANNING AND
IMPLEMENTATION: TREATING UNCERTAINTY IN COMMERCIAL
OPERATION DATES AND INCREASING AUCTION EFFICIENCY

Rafael de Sá Ferreira

Tese de Doutorado apresentada ao Programa de Pós-graduação em Engenharia Elétrica, COPPE, da Universidade Federal do Rio de Janeiro, como parte dos requisitos necessários à obtenção do título de Doutor em Engenharia Elétrica.

Orientador: Carmen Lucia Tancredo Borges

Rio de Janeiro
Fevereiro de 2018

IMPROVEMENTS TO TRANSMISSION EXPANSION PLANNING AND
IMPLEMENTATION: TREATING UNCERTAINTY IN COMMERCIAL
OPERATION DATES AND INCREASING AUCTION EFFICIENCY

Rafael de Sá Ferreira

TESE SUBMETIDA AO CORPO DOCENTE DO INSTITUTO ALBERTO LUIZ
COIMBRA DE PÓS-GRADUAÇÃO E PESQUISA DE ENGENHARIA
(COPPE) DA UNIVERSIDADE FEDERAL DO RIO DE JANEIRO COMO
PARTE DOS REQUISITOS NECESSÁRIOS PARA A OBTENÇÃO DO GRAU
DE DOUTOR EM CIÊNCIAS EM ENGENHARIA ELÉTRICA.

Examinada por:



Prof. Carmen Lucia Tancredo Borges, D.Sc.



Prof. Djalma Mosqueira Falcão, Ph.D.



Prof. Amaro Olímpio Pereira Junior, Ph.D.

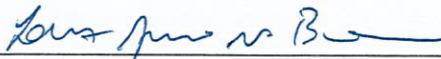

Dr. Luiz Augusto Nóbrega Barroso, D.Sc.



Prof. Alexandre Street de Aguiar, D.Sc.



Dr. Mario Veiga Ferraz Pereira, D.Sc.

RIO DE JANEIRO, RJ - BRASIL

FEVEREIRO DE 2018

Ferreira, Rafael de Sá

Improvements to transmission expansion planning and implementation: treating uncertainty in commercial operation dates and increasing auction efficiency/ Rafael de Sá Ferreira. Rio de Janeiro: UFRJ/COPPE, 2018.

IX, 148 p.: il.; 29,7 cm.

Orientador: Carmen Lucia Tancredo Borges

Tese (doutorado) – UFRJ/ COPPE/ Programa de Engenharia Elétrica, 2018.

Referências Bibliográficas: p. 131-136.

1. Concessões de transmissão. 2. Leilões combinatórios. 3. Planejamento da expansão da transmissão. I. Borges, Carmen Lucia Tancredo. II. Universidade Federal do Rio de Janeiro, COPPE, Programa de Engenharia Elétrica. III. Título.

AGRADECIMENTOS

Gostaria de expressar minha gratidão a todos que me apoiaram, direta ou indiretamente, na elaboração desta dissertação: Aureo Ferreira, Tiago Ferreira, Maria Izabel Sá, Beatriz Amorim, Martha Carvalho, Cecília Abreu, Stener Abreu, Carmen Borges, Luiz Barroso, Mario Pereira, Luiz Mauricio Thomé, Pedro Antmann, Jorge Trinkenreich, José Rosenblatt, André Dias, Sergio Granville, Jairo Terra, Gustavo de Vivero, Gabriel Rocha, Renato Haddad, Thiago Ivanoski, Emílio Matsumura, Patrícia Nunes, Thiago Ferreira, Arina Anise, Bernardo Bezerra, Raphael Chabar, Rafael Kelman, Amílcar Guerreiro, Marina Dietze, Lujan Latorre, Gerson Oliveira, Luiz Carlos da Costa, Fernanda Thomé, Silvio Binato, Djalma Falcão, Wadaed da Costa, Alessandro Moreira, Maria Helena Vale, Antônio Braga, Daniele Oliveira, Ronald Voelzke, Andreas Ettlinger, Ralph Hendriks, Guntram Schultz, Estevão Cruz, Antônio José Lima, Vitor Haase, Raul Duarte, Gabriel Cunha e todos os familiares, amigos, colegas de trabalho e de estudo que merecem sinceros agradecimentos.

Resumo da Tese apresentada à COPPE/UFRJ como parte dos requisitos necessários para a obtenção do grau de Doutor em Ciências (D.Sc.)

CONTRIBUIÇÕES AO PLANEJAMENTO E IMPLANTAÇÃO DA EXPANSÃO DA TRANSMISSÃO: TRATAMENTO DE INCERTEZAS EM DATAS DE ENTRADA EM OPERAÇÃO COMERCIAL E AUMENTO DE EFICIÊNCIA EM LEILÕES

Rafael de Sá Ferreira

Fevereiro/2018

Orientador: Carmen Lucia Tancredo Borges

Programa: Engenharia Elétrica

Esta tese apresenta três contribuições ao planejamento e implantação da expansão da transmissão. Primeiro, propõe-se usar leilões combinatórios e leilões descendentes simultâneos para tratar o problema da exposição em leilões multi-itens de concessões de transmissão, aumentando a eficiência destes leilões, e apresenta-se um arcabouço de simulação para quantificar os benefícios potenciais do uso de tais protocolos. Segundo, propõe-se uma metodologia de planejamento da expansão que considera explicitamente incertezas em tempos de implantação de instalações da transmissão ao determinar as adições de capacidade e as datas de início de implantação de ativos. Terceiro, aplica-se conceitos da teoria do agente-principal para propor uma abordagem para otimizar o desenho de mecanismos de seleção do vencedor e de partilha de riscos, de modo a gerir incertezas em tempos de implantação de ativos, no contexto em que mecanismos competitivos são utilizados para selecionar os agentes a que contratos de transmissão implantação são concedidos. Para todas as três propostas, utiliza-se abordagens de otimização clássica, notadamente programação inteira linear mista, para a formulação matemática que subsidia simulações e análises; e retira-se dos resultados numéricos de estudos de casos conclusões qualitativas que subsidiem planejadores e reguladores.

Abstract of Thesis presented to COPPE/UFRJ as a partial fulfillment of the requirements for the degree of Doctor of Science (D.Sc.).

IMPROVEMENTS TO TRANSMISSION EXPANSION PLANNING AND
IMPLEMENTATION: TREATING UNCERTAINTY IN COMMERCIAL
OPERATION DATES AND INCREASING AUCTION EFFICIENCY

Rafael de Sá Ferreira

February/2018

Advisor: Carmen Lucia Tancredo Borges

Department: Electrical Engineering

Three proposals contributing to the electricity transmission expansion planning and implementation process are presented in this thesis. The first proposal refers to the use of combinatorial and simultaneous descending auctions to treat the exposure problem and increase the efficiency of multi-item transmission auctions. A simulation framework to quantify potential benefits of using these auctions protocols, for transmission companies and grid users, is proposed. The second proposal refers to an expansion planning methodology that explicitly accounts for uncertainties in facility implementation times while determining the capacity additions and their optimal implementation schedule. In the third proposal, principal-agent theoretic concepts are applied to develop a methodology for the optimal design of winner-selection and risk-sharing mechanisms, with the goal of managing uncertainties in implementation times of transmission facilities, when competitive processes are used to select the agents to which concessions to implement and operate these facilities are awarded. Classical optimization approaches, notably mixed-integer linear programming, are used in the mathematical formulations that underlie the simulation and analyses carried out for all three proposals; and qualitative conclusions aiming at aiding planners and regulators are drawn from the quantitative results of case studies.

TABLE OF CONTENTS

1	INTRODUCTION	1
1.1	Background and motivation	1
1.1.1	Competitive bidding for transmission facilities	2
1.1.2	Uncertainties in implementation times of transmission facilities.....	7
1.2	Scope of work of doctoral thesis.....	11
1.2.1	Objectives and technical contributions.....	11
1.2.2	Relevance, novelty and technical elaboration	12
1.3	Organization of the document.....	14
1.4	Papers submitted to or already accepted by technical journals as a result of this work	16
2	COMBINATORIAL AND SIMULTANEOUS DESCENDING AUCTIONS AS MECHANISMS TO AWARD TRANSMISSION CONCESSIONS.....	17
2.1	Motivation and objectives	18
2.2	Literature review and novelties of the approach.....	20
2.3	Problem characterization.....	21
2.3.1	Exposure problem and the sequential auction	21
2.3.2	Combinatorial auction	23
2.3.3	Simultaneous descending auction.....	23
2.3.4	The choice of auction protocols to deal with the exposure problem.....	24
2.4	Mathematical formulation.....	27
2.4.1	Combinatorial auction	27
2.4.2	Simultaneous descending auction.....	30
2.4.3	Sequential auction	39
2.5	Case studies and discussion	39
2.5.1	Case study A: small-scale auction	40
2.5.2	Case study B: mid-sized auction	46
2.5.3	Case study C: large-scale auction.....	50
2.6	Conclusions.....	52
3	TRANSMISSION EXPANSION PLANNING UNDER CONSIDERATION OF UNCERTAINTIES IN FACILITY IMPLEMENTATION TIMES	56
3.1	Motivation and objectives	57
3.2	Literature review and novelties of the approach.....	58

3.3	Problem characterization.....	58
3.4	Methodology and mathematical formulation.....	60
3.4.1	Starting with the problem without uncertainties in implementation times.....	60
3.4.2	Representation of scenarios of implementation times.....	65
3.4.3	Mathematical formulation of the problem considering uncertainties in facility implementation times.....	68
3.5	Case study and discussion.....	72
3.5.1	Input data.....	72
3.5.2	Results.....	79
3.6	Conclusions.....	83
4	MANAGING UNCERTAINTIES IN IMPLEMENTATION TIMES OF COMPETITIVELY-PROCURED TRANSMISSION VIA OPTIMAL DESIGN OF RISK-SHARING AND WINNER SELECTION FUNCTIONS.....	86
4.1	Motivation and objectives.....	87
4.2	Literature review and novelties of the approach.....	91
4.3	Problem characterization.....	92
4.3.1	Systemic costs in the absence of planned transmission.....	93
4.3.2	Shape of winner selection and risk-sharing functions.....	94
4.3.3	Competitive bidding & definition of transmission contract.....	97
4.3.4	Uncertainties seen by transcos and principal, information asymmetries and robust-decision making of the principal.....	98
4.4	Mathematical formulation.....	100
4.4.1	Detailing the problem of the transco.....	102
4.4.2	Detailing the problem of the principal.....	105
4.5	Case studies and discussion.....	109
4.5.1	Case study A: analyzing several aspects of the problem.....	110
4.5.1.1	A first look at the impacts of bidder participation uncertainty.....	110
4.5.1.2	Limits to positive incentives, risk-aversion, and efficiency.....	112
4.5.2	Case study B: a deeper look at impacts of uncertainties.....	116
4.6	Conclusions.....	119
5	SUMMARY OF CONCLUSIONS AND POSSIBLE FUTURE EXTENSIONS OF THE WORK.....	122

5.1	Combinatorial and simultaneous descending auctions for transmission concessions.....	122
5.1.1	Summary of main conclusions	122
5.1.2	Possible future extensions of the work.....	124
5.2	Transmission expansion planning under consideration of uncertainties in facility implementation times.....	124
5.2.1	Summary of main conclusions	124
5.2.2	Possible future extensions of work.....	126
5.3	Management of uncertainties in implementation times of competitively-procured transmission via optimally designed risk-sharing and winner selection functions.....	127
5.3.1	Summary of main conclusions	127
5.3.2	Possible future extensions of the work.....	129
	REFERENCES	131
6	APPENDIX A: COMBINATORIAL AUCTION AS TOOL TO SELECT EXPANSION CANDIDATES	137
6.1	Problem setup and methodology.....	137
6.2	Case study and discussion.....	141
6.2.1	Input data	141
6.2.2	Results	143
6.2.3	Discussion and conclusions.....	144
7	APPENDIX B: EXAMPLE OF ESTIMATION OF PROBABILITY DISTRIBUTION OF DELAYS VIA TREATMENT OF HISTORICAL DATA	145

1 INTRODUCTION

This introductory chapter begins with a brief presentation of the background and the motivation for the development of the research that lead to this document, in section 1.1. In section 1.2, the scope of work of the doctoral thesis is presented, with focus on the objectives and the technical contributions of the work. Section 1.2 summarizes the items of the scope of work, highlighting their relevance, novelty and technical elaboration, according to the perception of the author of this thesis. Section 1.3 describes the organization of this document. The chapter ends with an enumeration of the papers submitted to or already accepted by technical journals as a result of this work, in section 1.4.

1.1 Background and motivation

The proposals and technical contributions of this work deal with two fields of knowledge: auctions to award concessions to implement and operate transmission facilities; and transmission expansion, including planning and implementation, considering uncertainties in the date at which facilities enter operation. The two fields relate to each other due to auctions being used to select agents that implement transmission expansion.

This thesis aims at proposing improvements to these two fields of knowledge, with three main proposals being presented. On the one hand, the proposals of chapters 2 and 4 aim at increasing efficiency in auctions to award transmission concessions. On the other hand, the proposals of chapters 3 and 4 have the goal of improving transmission planning and implementation when planners and entities in charge of executing transmission auctions face uncertainties regarding the times needed to implement transmission facilities. The link between these two objectives is a practical one: as auctions are used in several institutions to select the agents who will implement transmission facilities under a concession contract or another functionally similar

instrument, the possibility of using the auctions (both the winner selection mechanism and incentives to the agent embedded in the contract being auctioned) to manage implementation uncertainties in an efficient manner is a topic of interest.

Therefore, the connection between the proposals of this thesis is *functional* in nature, meaning that they serve the common overarching objective of improving transmission planning and implementation. Yet, the reader will notice that the proposals of chapters 2, 3 and 4 can also be understood and applied independently.

In order to understand the motivation for this work, background information on two topics must be provided: (i) competitive bidding processes (notably, auctions) as means to award transmission concessions or similar authorizations to agents; and (ii) delays in the commercial operations date of transmission facilities, signaling increasing uncertainties in implementation times of transmission facilities. These topics are approached in sections 1.1.1 and 1.1.2 below.

1.1.1 Competitive bidding for transmission facilities

In several jurisdictions where the power sector has been liberalized and subject to vertical unbundling, and where the participation of non-incumbent agents in the electricity transmission segment is allowed, competitive processes are used to bestow concessions to implement and operate transmission facilities upon agents.

Auctions are the most common competitive processes used for this purpose. For instance, they are used in several Latin American countries, such as Brazil [1], Chile [2]-[3], Colombia [4] and Peru [5]. All of these countries combine determinative centralized transmission expansion planning with a decentralized implementation and operation of the assets¹, with competitive bidding being used to select private or public

¹ In some of the countries, private agents can also develop transmission facilities that are not included in transmission expansion plans developed by centralized planning agencies. These arrangements are subject to specific regulations regarding remuneration of assets or even their transferring to transmission companies. Yet, the development of determinative plans for transmission expansion mechanism by a central planning agency is an existing mechanism in all of these jurisdictions. Also, competitive bidding

agents to which concessions or similar governmental authorizations to provide electricity transmission services² will be awarded.

Other jurisdictions have recently implemented or are currently implementing competitive processes to select agents upon which concessions or other forms of governmental authorizations to provide electricity transmission services, or at least certain activities of this services, will be bestowed:

- In Mexico, the Electricity Industry Law [6] established that: (i) the state-owned incumbent utilities responsible for transmission services may constitute associations with private agents to execute, among other activities, the financing, installation, maintenance, management and operation of the infrastructure required to provide these services; and (ii) competitive bidding processes shall be used to select the agents to which the contracts and agreements that constitute the associations will be awarded.
- In the USA, FERC Order 1000 [7] removed in 2012 the right of first refusal of incumbent transmission service providers over new regional transmission facilities. This Order also allowed, but did not require, that competitive bidding is used to solicit transmission projects or project developers. Competitive bidding processes have ever since been used by ERCOT, CAISO and PJM³, among other regional transmission organizations.

processes are used in all of the mentioned countries to award concessions or functionally similar governmental authorizations to implement and operate greenfield assets and provide transmission services. However, in all of these countries, assets representing reinforcements to existing transmission infrastructure are either obligatorily implemented and operated by existing transmission agents, or these agents at least have the right of first refusal for their implementation and operation.

² In a simplified explanation, *providing electricity transmission services* means which means implementing and operating transmission facilities, and being remunerated for this.

³ Competitive bidding processes with different models have been used in the USA. In some cases, the regional transmission operators identify needs and solicit proposals for solutions from transmission service providers, and in this case the providers specify the nature and technical characteristics of the

- In the Canadian province of Alberta, amendments to the Transmission Regulation dated from 2010 mandated the Alberta Electric System Operator to develop and implement a competitive bidding process to select agents to implement and operate critical transmission infrastructure [8]-[9]. Ontario also used competitive processes for electricity transmission [10].

Even though competitive processes in some of the abovementioned jurisdictions are more properly characterized as *beauty contests*⁴, in most of them the selection can be basically characterized as an auction in which the selection criterion is primarily based on the revenues required to cover the costs of transmission companies that will implement and operate the facilities⁵.

network facilities (and even other types of facilities, including local storage, etc.) of their own solution. This type of process has been used, for instance, in PJM. In other cases, the regional transmission operator not only identifies systemic needs, but also specifies the exact nature and the technical characteristics of the transmission facilities, and the transmission service providers compete for the right to implement and operate (and in some cases own) this pre-defined solution. The latter type of process bears higher similarity with that used in the South American countries mentioned in the beginning of this section (Brazil, Chile, Colombia and Peru) and with that used in Alberta and Ontario (Canada) – in the USA, a process with these characteristics has been used, for instance, by ERCOT, CAISO, MISO and SPP.

⁴ A *beauty contest* is a competitive process (*different from* competitive bidding) in which awardees are selected with basis on their performance, evaluated by a jury committee, regarding a number of criteria. An example of such a competitive process is that used in the Canadian province of Ontario to select the transmission company to implement and operate the East-West Tie Line [10], in which proposals were evaluated with basis on criteria that included not only costs, but also other items, such as: (i) organization (project organizational plan, organizational structure, qualification of project management team and résumés of key management personnel, past experience with similar projects); (ii) First Nations and Métis (indigenous peoples) participation; (iii) landowner, municipal, and community consultations; (iv) First Nations and Métis consultation; (v) technical capacity; (vi) financial capacity. In this example of Ontario, all criteria have been given equal weights in the selection process, but this is not always the case in *beauty contests*.

⁵ Naturally, in all jurisdictions the technical, managerial and financial competences of the competing companies competing are assessed during the competitive process. In the context of auctions, these are usually evaluated during a qualification stage, and only the qualified companies are allowed to present

In many jurisdictions that use auctions with this format, the competing companies' bids corresponds directly to the revenues required to implement and operate the transmission facilities, and these revenues will be received by the company after the assets enter commercial operation. This is the case of Brazil, Chile and Colombia. In Brazil and Colombia, the bids basically correspond to the *total* annual revenues required by the company. In the Chilean case, the competitors' bids correspond basically to the same concept, with the difference that the bidders present *two separate figures*: (i) the annual revenue requirements associated with operational expenditures (administration, operation and maintenance); and (ii) those associated with remuneration/recovery of capital expenses.

In other jurisdictions that use auctions, the companies' bids contain information that can be directly used by the auctioneer to calculate the revenue requirements. This is the case of Peru – where the bids correspond to the investment values and the yearly revenue requirements to cover administration, operation and maintenance (AO&M) expenses – and Alberta – where the companies present a proposed financial structure and capital costs⁶ and cost information (excluding financial costs) that allow calculating the net present value of costs.

In many jurisdictions that use auctions to assign transmission concessions or similar forms of authorizations to explore the electricity transmission service⁷ there are several transmission facilities (and several concessions) auctioned each year. This is

bids in the actual *bidding* phase – a situation clearly different from that of the *beauty contests* (see definition in footnote 4).

⁶ More specifically, the information on the proposed financial structure and capital costs refers to: debt/equity structure, indicative cost of debt and return on equity [8].

⁷ In the remainder of this work, the term *transmission concession* will be used in reference not only to the concession *per se*, but also other forms of governmental authorizations to explore the electricity transmission service, under whichever formal business model – possible business models include concessions, associations with incumbent players (as in the model of Mexico), subsidiary companies and passive investment authorizations. The term *concession* is used in reference to all of these business models exclusively for the sake of notational conciseness, since many of them are not formally categorized as concessions.

notably the case of developing countries, where the transmission system typically expands rapidly to cope with a fast-growing electricity demand. For instance, in the last decade Brazil has been offering several thousands of kilometers of transmission lines and of MVA of transformation capacity in auctions each year [1]. Colombia carried out competitive tenders for 7 sets of transmission facilities from the trunk system⁸ in 2013, and another 7 in 2014 [4]. Peru, a relatively small-scaled country, auctioned 2 sets of transmission facilities in 2013 and 3 in 2014⁹ [11]. Even Mexico, a newcomer to the context of competitive bidding in transmission, is expected to hold tenders for 1,200 kilometers of transmission lines in 2016, and a total of 25 thousand kilometers in the near future [12].

Transmission auctions where several different facilities (grouped into several different concessions) are offered by the auctioneer can be seen as multi-item auctions, where the items are heterogeneous – i.e., each concession has different characteristics and, consequently, can be valued in potentially different manners by each of the companies participating in the auction. That is to say, each concession can be interpreted, in light of auction-theoretic concepts, as a heterogeneous item in a multi-item auction.

In this context, there may be complementarities or complementarities between different items in the auction. A combination of *complementary* items would have, for a given auction participant, a higher value than the sum of the individual values of each item. Conversely, a combination of *supplementary* items would have a lower value than the sum of the individual values, for a given participant [13]-[14].

⁸ These figures refer only to facilities of the *trunk national transmission system*. Facilities from the *regional transmission system* were also auctioned in these years.

⁹ Each set of transmission facilities included several transmission lines. In 2013, the sets of auctioned facilities were: (i) 220 kV transmission lines of axis Machupicchu - Quencoro - Onocora – Tintaya and associated substations; (ii) 500 kV transmission lines of axis Mantaro – Marcona – Socabaya – Montalvo and associated substations. In 2014, the sets were: (i) 220 kV transmission line of axis La Planicie – Industriales and associated substations; (ii) 220 kV transmission line Moyobamba - Iquitos and associated substations; (iii) 200 kV transmission line Friaspata - Mollepata and Orcotuna substation.

Whenever this is the case, there are opportunities to increase the efficiency of auctions by explicitly taking into account the complementary or supplementary nature of the heterogeneous items while designing the auction rules. These opportunities have not yet been systematically explored by the various countries that currently use auctions as means to award transmission concessions to competing agents.

Given the large range of countries that use auctions for this purpose, taking advantage of these opportunities to increase the efficiency of the multi-item auctions for transmission concessions may have a positive impact on several power systems, including these of various developing economies. This is the motivation for the investigation of *combinatorial auctions for transmission concessions* in this document.

1.1.2 Uncertainties in implementation times of transmission facilities

Delays in the implementation of transmission facilities have been verified in several countries around the world. These are not necessarily a recent phenomenon – historically, engineering issues and even labor-related problems have caused delays in the implementation of several infrastructure assets, including these used for electricity transmission. However, the increasing awareness about social-environmental impacts of transmission infrastructure has brought about a range of new issues (ranging from delays in social-environmental licensing processes to opposition from local groups) that significantly impacted the frequency and severity of delays in the commencement of operations of transmission facilities in recent times.

Many of the countries mentioned in the previous section have recently dealt with implementation delays and their impacts on transmission system expansion. In Brazil, chronic delays in the implementation of transmission infrastructure have been impacting the integration of renewable generators to the grid. Data from recent reports from the regulator regarding the status of transmission facilities under construction revealed that 62.3% of these facilities were delayed in the country [15].

The Ministry of Energy of Chile recognized, in June 2012, that the average delay in the implementation of large transmission infrastructure projects in Chile was of 18 months [16]. These problems persist in recent times: in December 2015, ISA, a private investor with activities in Chile, expressed concerns about the delay of the Polpaico – Cardones 500 kV transmission line, emphasizing that hurdles in social-environmental licensing were a key factor in this [17].

Delays in the commercial operation of transmission facilities superior to one year have also been reported in Colombia at least since 2013 [18].

The Peruvian regulator, Osinergmin, reported in December 2015 [19] that the transmission companies responsible from 5 out of 12 concessions being implemented at the occasion had requested a postponement of the target commercial operations dates (COD) of the assets¹⁰. A recent study from the Regional Energy Integration Commission (CIER, a regional institution) indicated in 2012 that procedures for establishing rights of way for transmission concessions were a key factor in explaining commissioning delays in the Peru.

Naturally, delays in the commissioning of transmission facilities are not a problem limited to South American countries – they have also been reported as a relevant problem in the USA [20], India and China [21].

Given the impact that significant delays in the commercial operations date of transmission facilities can have on the technical and commercial operation of power systems, some jurisdictions have been attempting to implement processes in which

¹⁰ The projects for which postponements of the target commercial operations dates were requested are: (i) the Mantaro - Marcona - Socabaya - Montalvo 500 kV transmission line, with a length 900 km, for which a postponement in the target COD of 193 days was requested; (ii) the Carhuaquero - Cajamarca Norte - Cállic - Moyobamba 220 kV transmission line, with a length of 402 km, for which a postponement in the target COD of 300 days was requested; (iii) the La Planicie - Industriales 220 kV transmission line, with a length of 17 km, for which a postponement in the target COD of 78 days was requested; (iv) the Friaspata - Mollepata 220 kV transmission line, with a length of 91 km, for which a postponement in the target COD of 81 days was requested; (v) the Orcotuna substation, for which a postponement in the target COD of 96 days was requested.

determinative transmission expansion plans are prepared with as much antecedence as possible with respect to the date in which the facilities would need to commence operations. System planners use the best information available to them to prepare these plans. Brazil and Chile are jurisdictions where efforts to conduct planning with as much antecedence as possible have been made, and Colombia has also considered its implementation.

However, this planning approach limits itself to plan with as much antecedence as possible to ensure that the decision to build a certain group of transmission facilities is also made with as much antecedence as possible with respect to the date at which facilities would need to be operational.

While this is certainly a step in the right direction, one could also consider the possible benefits of changing not only the *timing of the expansion planning efforts*, but *also the transmission expansion planning methodology* as a measure to mitigate the negative effects of delays in the COD of transmission facilities.

That is to say, while it is importance to conduct the expansion planning process with as much antecedence as possible, the planning function may also benefit from explicitly taking into consideration the possibility of implementation delays – and the underlying uncertainties in the time spans required to implement transmission facilities. While the practice of conducting the expansion planning process with as much antecedence as possible has the ultimate goal of *making the determinative decisions about transmission expansion available as early as possible*¹¹, the practice of adapting the planning methodology aims at ensuring that the *decisions themselves are adjusted to a context where delays are possible and implementation times are therefore uncertain*. The resulting changes in the expansion planning decisions may refer to the *nature* of the transmission facilities included in the plan (*what* to implement) and also to their *schedule* (*when* to initiate the implementation).

¹¹ In order to allow that the process of implementation of transmission facilities, which in many countries begins with the auction of the associated concessions, also begins with as much antecedence as possible with respect to the date when the facilities would need to be operational.

Given the prevalence and severity of delays in the COD of transmission facilities in several power systems around the world, this document aims at investigating and proposing a transmission expansion planning methodology that explicitly takes the possibility of delays and the resulting uncertainty in commercial operation dates into account. The possible benefits regarding the technical and commercial operation of power systems serve as a motivation for this endeavor.

But approaching the problem of uncertainty in implementation times of only the transmission facilities only in the planning stage has its limitations.

The possibility of lengthy implementation times for transmission facilities may be explained not only by factors related to the *context* in which they are implemented (such as geological hurdles that may require more sophisticated engineering solutions), but also to the *performance* of the agents that are responsible for implementing them. This represents a first motivation to seek to use competitive bidding processes to manage uncertainties in transmission implementation times.

A second reason to seek to manage uncertainties in transmission implementation times via a careful design of the competitive bidding process has to do with information asymmetries. Agents that will implement facilities may have better information on the possible contextual hurdles that will be faced in that implementation than planners and entities in charge of designing auctions. This is because these agents have extensive experience with all steps of the implementation process – including engineering, social-environmental licensing, procurement of materials and equipment, civil works, montage and commissioning. Furthermore, these agents may seek to avoid revealing their own efficiency in overcoming these challenges within the competitive bidding process.

For these reasons, seeking an optimal design of competitive processes used to select agents that will implement and operate transmission facilities, in order to optimally manage uncertainties in the implementation times of these facilities, is also a topic of interest for planners and regulators. The motivation to propose such a scheme arises from the finding that both the use of auctions to award transmission concessions and the occurrence of delays in the commercial operations of transmission facilities are

seen in several countries around the world, notably developing countries. Benefits from this scheme could therefore positively impact several power systems.

1.2 Scope of work of doctoral thesis

This section aims at presenting the scope of work of the doctoral thesis. The objective and technical contributions of this work are presented in section 1.2.1. Section 1.2.2 summarizes the relevance of the work, leveraging on the description of the motivation of section 1.1, and also presents remarks about the novelty of the proposals and the technical elaboration of the work.

1.2.1 Objectives and technical contributions

The three objectives of the work are summarized schematically in Figure 1.1, which also depicts their relationship with the two main issues whose solution serves as a motivation for the proposals of the work.

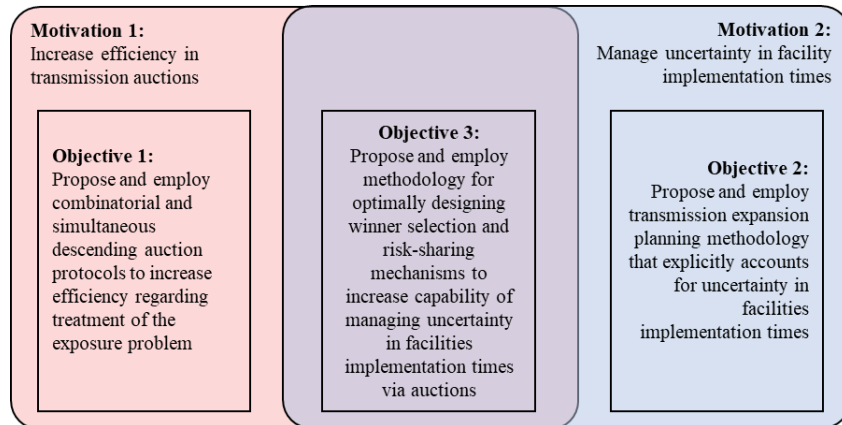

Figure 1.1: Schematic depiction of objectives of thesis and relation with two main motivations

The developments made to achieve objectives 1 to 3 are described in chapters 2 to 4 of this thesis. A short summary of the objectives is provided below.

- **Objective 1:** To propose and employ combinatorial auctions and simultaneous descending auctions to the context of awarding transmission concessions via competitive bidding processes, and to draw conclusions regarding the potential benefits, to grid users and transmission companies, of employing these auction protocols.
- **Objective 2:** To propose and employ a methodology for transmission system expansion planning that explicitly accounts for uncertainties in facility implementation times, and that results in optimal plans (*nature* and *schedule* of facilities to be implemented) when such uncertainties are relevant.
- **Objective 3** To propose and employ a methodology to optimally design winner selection and risk-sharing mechanisms in competitive bidding process to award transmission concessions, with the goal of managing information asymmetries and risks associated with uncertainties in implementation times of transmission facilities; and to draw practical conclusions regarding the use of such mechanisms.

1.2.2 Relevance, novelty and technical elaboration

This section characterizes each of the proposed items in the scope of work of the doctoral thesis, focusing on three attributes: relevance, novelty and technical elaboration. The considerations build up on the text presented in the previous sections.

Table 1.1 presents the summarized characterization of the three items in the scope of work, regarding each of the previously mentioned attributes.

Table 1.1. Characterization of scope of work regarding relevance, novelty and technical elaboration

Item of scope of work	Attribute and summarized characterization
<p>1. Proposal and use of combinatorial auction and simultaneous descending auction protocols to award transmission concessions to transmission companies participating in competitive bidding processes</p>	<p>Relevance: The application of the proposed combinatorial auction scheme (or of the simultaneous ascending auction scheme, with certain limitations) could increase the efficiency of auctions as mechanisms to select companies to which transmission concessions are awarded, in what concerns the <i>exposure problem</i>, which will be described in chapter 2. This could bring about positive impacts in several power systems that use competitive bidding processes to award transmission concessions.</p> <hr/> <p>Novelty: Though combinatorial auctions and simultaneous ascending¹² auctions have been widely study and used in practice in the telecommunications sector to award authorizations to commercially explore frequency bandwidths [22]-[23], their use in the transmission segment of the electricity industry was neither investigated by the academy nor used in practice. The proposals of the auction scheme and the investigation of possible effects of its use in the electricity transmission business are thus a technical contribution of this work. The contributions of the work refer to the adjustment of auction protocols to the context of electric transmission and the proposal of mathematical framework for simulation of application of these auction protocols.</p> <hr/> <p>Technical elaboration: The combinatorial auction scheme is in its nature a mixed-integer linear optimization problem, which was formulated and solved. The simultaneous descending auction requires an interaction process in which the auctioneer solves a trivial optimization problem, but the modeling of the bidders' behavior requires the formulation and solution of a mixed-non-linear optimization problem, which is linearized in this work. Both models are adapted to the context of reverse auctions in electricity transmission. The construction of realistic study cases requires modeling of intricate complementarities and complementarities between transmission concessions, from the developer point of view.</p>
<p>2. Methodology for transmission system expansion planning that explicitly accounts for implementation delays and uncertainties in the commercial operation dates of transmission facilities while determining the expansion decisions</p>	<p>Relevance: The frequency and severity of delays in the commercial operations dates of transmission facilities have been increasing in several jurisdictions, negatively impacting the technical and economic performance of several power systems. Proactive expansion planning efforts to deal with the matter have thus far been limited to advancing planning processes in time, in order to seek that determinative decisions on which facilities to build are available with as much antecedence as possible with respect to the time at which the assets would need to be operational. A formal approach to seek not only to advance the decisions in time as much as possible, but also to adjust the transmission expansion decisions, regarding the nature and target schedule of new facilities, represents a step further in the efforts to mitigate negative impacts of delays.</p> <hr/> <p>Novelty: Recent literature reviews [24] show that a methodology (including the mathematical formulation of an optimization problem) for transmission expansion planning under explicit consideration of uncertainties in the commercial operations dates</p>

¹² In the context of auctions for bandwidth for telecommunications, the participants' bids usually correspond to a payment made in exchange for the right to commercially explore a certain frequency interval. Since the bidder with the highest payment wins the auction, an *ascending* auction scheme is used. The situation is different from that typically verified in auctions for transmission concessions, where the participants' bids correspond to the revenues required to explore a certain concession and the participant that requires the lowest revenues wins. This is the reason for coning the expression *simultaneous descending auction* and using it in this thesis.

Item of scope of work	Attribute and summarized characterization
	<p>of transmission facilities is not currently available in the literature. Such a methodology represents a technical contribution of this work.</p> <hr/> <p>Technical elaboration: The expansion problem is in its nature (when using the linearized model of network behavior) a multi-stage stochastic mixed-linear-integer optimization problem, which was formulated and solved. The integer (binary) decisions refer to the <i>date at which the implementation of the transmission facilities should be initiated</i>. Yet, a specific class of uncertainties is relevant for this problem: the implementation delays affect the date at which a facility will actually come online, given that date at which the beginning of the implementation was decided. Notice that, if there are delays, the <i>actual COD</i> (the <i>outcome</i>) will not be deterministically set even if the <i>date at which the implementation starts</i> (the <i>decision</i>) is set deterministically. This required the development of a specific mathematical formulation to <i>shift</i> the actual COD given the value of a decision variable that is only available as a result of the optimization problem.</p>
<p>3. Propose and employ methodology for optimally designing winner selection and risk-sharing mechanisms to increase capability of managing uncertainty in facilities implementation times via auctions</p>	<p>Relevance: It is important to deal with uncertainty in implementation times of transmission facilities also during the implementation stage – more precisely, within the process through which the agent responsible to implement and operate the facility is selected. This is particularly relevant given the information asymmetries that the planner and the regulator may perceive and that prevent the use of perfect information in the transmission expansion planning process. The practical conclusions could be of use in several countries which use competitive bidding to select transmission agents and that currently face the issue of uncertain transmission implementation times and delays, as indicated in section 1.1.2.</p> <hr/> <p>Novelty: Principal-Agent theoretic concepts have not yet been used for this application, which makes the proposed approach new. Our focus on incentives targeted at implementation times of transmission leads to the extension of classical agent-principal approaches to incorporate the following: (i) the systemic costs due to the absence of a planned transmission facility change with the antecedence with which delays are detected; (ii) the time dimension of the problem is fully represented, adding to the complexity of the problem and impacting the formulation – a MILP framework is used to enable computational tractability. More details on the novelty of the approach are available in section 4.2.</p> <hr/> <p>Technical elaboration: The principal-agent theory [25], which represents the theoretical foundation for the design of the incentive structure mentioned at left, requires that the principal models how the agent will react to its decisions, while taking these decisions. For reasons explained in chapter 4, the problem was not directly modeled as a single bilevel optimization problem – though a simulation framework that approximates this approach under a discretization of the decision space of the principal was developed. Both the problem of the agent and the problem of the principal were modeled as mixed-integer linear programs, and the interactions among the two were made via a discretization of the decision space of the principal. Also, reformulations of terms including decisions variables as the limits of summations, which are fit to be used in a mixed-integer linear programs, were developed.</p>

1.3 Organization of the document

The remainder of this document is organized as follows:

Chapter 2 focuses on the design and application of combinatorial and simultaneous descending auction schemes to award transmission concessions to transmission companies participating in competitive bidding processes.

Chapter 3 proposes a methodology for transmission system expansion planning that explicitly accounts for implementation delays and uncertainties in the commercial operation dates of transmission facilities while determining the expansion decisions.

Chapter 4 deals with the optimal design of risk-sharing and winner-selection mechanisms to manage uncertainties in implementation times of transmission facilities, when competitive bidding processes are used to select the agents to which concessions to implement and operate these facilities.

In each of these chapters, the following structure is used: (i) the first section deepens the motivation and objectives for the developments; (ii) the second section contains a review of the technical literatures and an identification of the novelties of the work; (iii) the third section provides a conceptual characterization of the problem at hand and the proposed solution; (iv) the fourth section details the proposed methodology and its mathematical formulation; (v) the fifth section contains case studies, including a discussion of numerical results; and (vi) the sixth section presents the main conclusions of the work.

Chapter 5 presents a summary of the conclusions, merely summarizing the conclusions already presented in each of the chapters 2 to 4, and then proceeds to presenting possible future extensions of the work.

Bibliographical references are found at the end of this document. Appendix A contains an example of an extension of the combinatorial auction protocols as a tool to aid transmission expansion planning – a more theoretical application not discussed in the main body of text. Appendix B contains an example of the application of one of the possible methods to estimate probability distributions of implementation times of transmission facilities. The estimation of these probability distributions is required to obtain the input data for the approaches proposed in chapters 3 and 4.

1.4 Papers submitted to or already accepted by technical journals as a result of this work

The following paper, which corresponds to reference [26] of this document and was elaborated as a result of the work that led to chapter 2 of this thesis, has already been accepted for publication by a technical journal, and is available online in the website of IEEE since October 2017:

R. Ferreira, C. Borges, L. A. Barroso. "*Combinatorial and simultaneous descending auctions for electricity transmission concessions*", to appear in IEEE Transactions on Power Systems, accepted for publication in October 2017.

The following paper, which corresponds to reference [27] of this document and was elaborated as a result of the work that led to chapter 4 of this thesis, has been submitted to a technical journal and is currently under review:

R. Ferreira, C. Borges, L. A. Barroso. "*Managing uncertainty in implementation times of competitively-procured transmission via risk-sharing and winner selection functions*", submitted to IEEE Transactions on Power Systems in November 2017.

A paper that deals with the developments of chapter 3 of this thesis is yet to be prepared and submitted to a technical journal.

2 COMBINATORIAL AND SIMULTANEOUS DESCENDING AUCTIONS AS MECHANISMS TO AWARD TRANSMISSION CONCESSIONS

This chapter deals with the topic of combinatorial auctions and simultaneous descending auctions as mechanisms to award transmission concessions and to select concessionaires among companies participating in competitive bidding processes. The focus is on assessing the ability of these auction protocols to deal with the exposure problem, and on evaluating potential benefits of their application to the transmission segment.

The chapter is organized as follows:

- Section 2.1 deepens the motivation presented in the introductory chapter of this document and presents the objectives of this chapter;
- Section 2.2 contains a review of the technical literature and presents the novelties of the work;
- Section 2.3 characterizes the problem at hand, introducing concepts relevant for understanding the proposed mathematical formulation;
- Section 2.4 presents the proposed mathematical formulation to solve the problem at hand;
- Section 2.5 presents case studies and discusses their results;
- Section 2.6 contains the main conclusions of the work;

Possible future extensions of the work are presented in section 5.1.2 (chapter 5).

The nomenclature used in the mathematical formulation of this chapter should be taken independently of the nomenclature used in the other chapters of this document.

2.1 Motivation and objectives

In several countries where the power sector was subject to vertical unbundling and non-incumbents participate in the transmission segment, competitive bidding is used to select agents to which concession contracts or similar authorizations to implement and operate transmission facilities are awarded. Processes with winners selected on the basis of price offers are widely used, even when technical qualification stages precede the price-based competition. More exactly, competition often focuses on the revenues required by the transmission company (transco) to explore the concession. Competitors state their revenue requirements (RR) – usually, annual RR fixed in real terms or a predefined schedule of RR varying across years – and the agent with the lowest RR is declared the auction winner. Processes with these features, referred to here as *transmission auctions*¹³, are used in many countries – e.g., Brazil, Chile, Colombia, and Peru [28] in Latin America.

There can be several facilities auctioned each year in these jurisdictions. Functionally interdependent facilities are usually grouped together for purposes of the auction, and concessions to implement and operate each resulting set of facilities are auctioned. The number of concessions auctioned each year can be high: Brazil offered circa 50 items in auctions held in 2016; Colombia auctioned 7 sets of facilities in 2013 and 7 in 2014 [28].

¹³ This document approaches auctions with the previously described characteristics, in which a planning authority determines the set of transmission facilities best fit to meet a predefined systemic need, and uses an auction to select the agent that requires the lowest revenues to implement and operate these facilities. Another type of competitive process, not addressed in this document, refers to the situation in which the planning authority identifies the systemic need but uses an auction in which agents have a more active role: basically, they propose both the nature of the technical solution (including the set of transmission facilities) to meet the systemic need and the revenues required to implement and operate it. This alternative type of competitive process has been termed the needs-based method in the technical literature and it has been used in some jurisdictions in the USA, including ISO-NE, NYISO and PJM [29],[30].

Transmission auctions for several different concessions are multi-item auctions with heterogeneous items [31]: each facility set has different characteristics and each transco may value them differently. Combinations (packages) of items may be *complementary* or *supplementary*. The RR an agent requires for a package of complementary items is lower than the sum of the RR required to explore each concession separately. Conversely, an agent requires higher RR to explore concessions of a supplementary package, or may not be interested in it at all. The valuation of complementarities can vary per transco – e.g., due to technical expertise or ease of access to resources.

Yet, prevailing transmission auction designs (notably in the countries mentioned as examples so far) do not offer bidders full possibilities of capturing these synergies between items. Except for a few preliminary experiences in Brazil¹⁴, *sequential auction* (SA) protocols are typically used: concessions are auctioned sequentially, and the auction of any item begins only after the winner (agent to which concession is awarded) of the previous one is known. If items are auctioned sequentially, risk-averse bidders cannot be certain of concomitantly winning all items of a complementary package of their interest, leading to lost opportunities to optimize auction results. This is known as the exposure problem [31],[32]: since a bidder cannot be certain of his ability to win or lose all items in a given combination whose value differs from the sum of the values of the items taken individually, he is discouraged from considering complementarities and complementarities while bidding, and not considering these lead to less efficient auction results. The exposure problem is approached in more detail in section 2.3.

The main goal of this chapter is to present auction protocols that can be used to mitigate the exposure problem and evaluate the potential for their use in transmission auctions, including the benefits (for transmission agents and for grid users) of capturing

¹⁴ An auction protocol resembling the simultaneous ascending auction protocol described here, but not entirely matching its capabilities of treating the exposure problem, was successfully used in Brazil for a pre-defined package of items in 2014. Despite limitations of the protocol used, there is evidence it resulted in a decrease in revenues required by the auction winner by 2.4%.

complementarities between different concessions. The focus is on *combinatorial* and *simultaneous descending auctions* (CA & SDA).

2.2 Literature review and novelties of the approach

Auction protocols that allow treating the exposure problem, including combinatorial and simultaneous descending auctions, have been studied and used in other infrastructure segments, notably in telecommunications (see [22]-[23],[33]-[34]), where complementarities affect frequency spectrum auctions. But, to the best of our knowledge, these protocols have not yet been formally studied for power transmission, though transmission auctions are used or considered for use in many countries. Iterative multi-item auctions for energy contracts have already been formally studied (e.g., in [35]-[36]), but these cannot be characterized as multi-item auctions of heterogeneous items as in the case of auctions for various transmission concessions.

The main contributions of the work presented in this chapter are twofold: (i) numerically investigating potential benefits of using protocols that allow treating the exposure problem in multi-item transmission auctions, with aid of small- and large-scale case studies; and (ii) presenting mathematical models, based on mixed-integer linear programming (MILP), for assessing the performance of CA & SDA protocols, as well as sequential auctions (SA) that will serve as comparison benchmarks, with respect to their ability to treat the exposure problem in transmission auctions.

We emphasize that some of the mathematical models and auction rules presented in this chapter consist in direct adaptations of approaches presented in previous technical work on auctions. As described in section 2.4: (i) the MILP models for the winner selection and pricing subproblems of the CA protocol are direct adaptations of similar protocols proposed in the technical literature, adjusted to allow their use in reverse auctions for transmission concessions; (ii) the rules of the SDA protocol consist in a direct adaptation of a subset of rules commonly employed in the telecommunications industry, also adjusted to fit reverse auctions of transmission

concessions. Thus, the main contributions of this work refer not to the proposal of such models, but rather to their adaptation to the context of transmission auctions and, notably, in their use to evaluate potential benefits, to transcos and grid users, of employing auction protocols that allow dealing with the exposure problem in multi-item auctions of heterogeneous sets of transmission facilities. It is worth mentioning that the optimization framework employed to model bidder behavior under the SDA protocol was developed by the author to enable the quantitative assessments of this chapter.

Our analyses purposefully focus on the exposure problem. Other features of the analyzed protocols, including their ability to avoid the winner's curse or hinder collusion, are not analyzed here despite of their importance in real applications. In view of this, our bidding model for transcos participating in auctions does not consider strategic behavior. The motivation for these modeling choices is exposed in section 2.3.

2.3 Problem characterization

2.3.1 Exposure problem and the sequential auction

Section 2.1 mentioned complementarity and supplementarity in multi-item transmission auctions. Consider the example of two concessions with facilities in adjacent regions, allowing any bidder that wins both of them in an auction to capture operation and maintenance (O&M) synergies. The bidder can require lower revenues to explore both concessions than the sum of the RRs for each separate item. In a sufficiently competitive auction with price-based winner selection, this can benefit bidders and grid users from which RRs are collected. The situation exemplifies a complementarity between concessions, but other examples are possible: technological similarity, scale/scope economies, etc.

Strict supplementarity, where a bidder requires a higher RR for a set of two or more items than that sum of the RR required for each item individually and may therefore avoid acquiring these items simultaneously, is less common in electricity

transmission. Yet, budget constraints can have functionally similar effects on bidders, leading transcos to avoid the concomitant acquisition of particular sets of items.

Valuations of complementarities or complementarities can differ per bidder: e.g., a holding with an EPC (engineering, procurement and construction) company among its subsidiaries perceives more synergies in constructing a pair of concessions requiring similar technological skills for their implementation than an auction participant outsourcing EPC. Another example: a transco that already holds facilities in a given region would perceive stronger opportunities to capture costs reductions for a package of new neighboring facilities

Transmission auctions are thus multi-item auctions with heterogeneous items; and the value of packages can vary per bidder. If, under these conditions, auction protocols expose bidders to the possibility of winning some, but not all, of the items in a given package, the *exposure problem* becomes an issue [23],[31], and inefficiencies of two basic types may occur:

- 1) Agents may bid aggressively expecting to win all items in a package, but actually win only a subset of them and fail to capture synergies. If this happens, agents may have difficulties in fulfilling contractual obligations: since the agent required lower revenues due his expectation of winning a package of complementary items, but actually won only a subset of the package, the awarded revenues may actually be below these needed to implement and operate the facilities under the standards specified in the contracts.
- 2) Considering the chance of not winning all items in a package, agents may ignore complementarities while bidding.

SA protocols in transmission auctions are subject to the exposure problem. Since each item is only auctioned after the winner for previous one is known, bidders cannot be sure on whether they will win any items that will be offered only in subsequent stages, and thus cannot ensure that the packages that are relevant to them will be won or lost integrally.

2.3.2 Combinatorial auction

The CA protocol [31] mitigates the exposure problem, thus enhancing auction efficiency. Agents present bids for packages of items, and these *package bids* are treated as indivisible: they will be either accepted or rejected integrally.

The winner selection problem solved by the auctioneer is: choose which bids to accept to optimize a given merit index, while ensuring that packages bids are accepted or rejected integrally and that any item is allocated to a single bidder. In the transmission auctions of interest for this chapter, where concessions are allocated to bidders requesting the lowest RR, the merit index to be minimized by the auctioneer corresponds to the total revenue requirements of accepted bids.

After selecting winners, the auctioneer determines the RR each of them will receive for exploring the concessions in the winning package. Section 2.4 describes the two pricing rules considered in this chapter for the CA: a first-price rule; and a second-price rule (Vickrey-Clark-Grove prices) [37],[38].

At this point, it is important to introduce a discussion on the *truthfulness* of the auction protocol. A protocol is said to be a truthful mechanism if the dominant strategy for any bidder is to present bids equal to his private valuation of the items (truthful bidding), independently of the bids presented by his competitors [39],[40]. The CA protocol with the VCG pricing rule is a truthful mechanism – under it, bidders are not able to improve their expected profit by bidding untruthfully.

2.3.3 Simultaneous descending auction

The SDA¹⁵ protocol [32],[33] also treats the exposure problem, but more loosely than the CA. In a SDA, agents can bid for each one of a set of individual items

¹⁵ In the telecommunications sector, simultaneous *ascending* auctions are used. As transmission auctions are typically *reverse* auctions (in which the bidder requiring the lowest RR wins), we use the expression simultaneous *descending* auction,

auctioned simultaneously. There are many items on the table concomitantly, and a price, corresponding to the lowest RR so far (*standing low bid*), is assigned to each one. The SDA is iterative: rounds (iterations) continue while the standing low bid changes for any item. As rounds pass, information on standing low bids is revealed and agents can modify bids. At the end, items are allocated to the bidders holding the corresponding standing low bids.

The SDA bidding rule does not allow directly presenting *indivisible* packages bids. Yet, the *simultaneous* revelation of bids for all items and the possibility that agents reallocate their resources by redefining bids as information is revealed allow bidders to indirectly build packages as rounds pass [31],[32]. The SDA thus offers some possibilities of treating the exposure problem, which justifies its analysis in this chapter.

The SDA pricing rule of the protocol employed in this chapter is straightforward: there is a single *price path* (a single sequence of prices as rounds pass [39]) and each winner will effectively receive a RR equaling his standing low bid for the items he wins at the end of the auction.

The SDA protocol described above is *not* a truthful mechanism, meaning that bidders would be able to employ strategies in which they react to the bids of competitors to maximize their own profits, presenting bids that differ from their private valuations of items, in the course of the auction.

2.3.4 The choice of auction protocols to deal with the exposure problem

The potential benefits of using protocols that offer bidders alternatives to deal with the exposure problem in auctions for transmission concessions will be illustrated in this chapter. Yet, regulators choosing among different auction protocols to deal with the exposure problem will need to consider phenomena that exceed those explicitly quantified in this chapter.

One of these phenomena concerns the performance of iterative auctions regarding truthfulness. As mentioned above, the SDA protocol investigated in this chapter is not a truthful mechanism. Yet, it is worth noticing that design of truthful protocols for iterative multi-item auctions of heterogeneous items has been addressed in the literature¹⁶. For instance, [39] presents a truthful protocol under the assumptions of a general private valuations model – this protocol maintains a single price path but allows actual final payments to differ from final standing bids. References [40]-[41] approach the problem with protocols employing multiple price paths in the auction (even if some of them are used only to calculate payments). Some of the previous work focuses on truthful protocols for iterative multi-item auctions of heterogeneous items that apply under more restrictive assumptions: e.g., [42] deals with the situation where there are gross substitutes¹⁷ valuations of the items.

While it is important to recognize that these sophisticated protocols for iterative auctions exist, formally investigating their applicability in the context of electricity transmission exceeds the scope of this work. Readers should bear in mind that, though truthfulness can be achieved via sophistication of the SDA, regulators interested in real applications are expected to examine whether the increased auction complexity (for the auctioneer and the potential bidders) may be a relevant enough practical hurdle to result in sophisticated SDAs not being the best fit for the necessities of a given jurisdiction.

In fact, regulators evaluating the applicability of different auction protocols for the transmission sector are also expected to consider evidence from practical uses of iterative auctions in other industries. For instance, [43] presents evidence that iterative auctions (in that reference, simultaneous ascending auction in the telecommunications industry) can also be prone to deter entrance of smaller bidders, and can facilitate strategic manipulation via signaling (an important element in collusion) and punishment

¹⁶ Notably, with focus on simultaneous ascending auctions, due to their history of use in the telecommunications industry, as previously stated.

¹⁷ Which is not the case of interest for this chapter, since electricity transmission concessions can be valued differently by different bidders, who can also value complementarities in different ways.

of rivals. Such phenomena, including strategic behavior, are not quantified in the simulations of this chapter.

Sealed-bid CA protocols such as the ones employed in this chapter also display disadvantages. For instance, some bidders may be discouraged from participating in the auction: (i) either due to the extensive amount of private information revealed to the auctioneer while presenting an extensive set of bids for different packages of transmission concessions; (ii) or due to the high costs incurred in producing this extensive set of bids for different possible packages before the auctions [23]-[33]. Regulators are also expected to consider these phenomena while evaluating the attractiveness of CA for transmission, though they are not modelled in this chapter.

The quantification of all relevant phenomena for the choice among different auction protocols exceeds the scope of this chapter. As already mentioned, the main goal of this work is to present protocols that can be used to mitigate the exposure problem in transmission auctions, thus offering insight on the potential for their use in this industry. This numerical investigation of potential benefits for transcos and grid users is expected to evoke discussions, in countries that use auctions to award transmission contracts, of the benefits of searching for solutions that allow dealing with the exposure problem.

Regulators and policymakers in each jurisdiction will need to take account of phenomena not fully modelled here while making their choices. Yet, we expect that: (i) the results of this chapter draw attention to the possible benefits of addressing the exposure problem in electricity transmission; (ii) fundamental features of different auction protocols are made clear to decision-makers; and (iii) the framework presented here facilitates the further development of mathematical models to aid decision-making, after the factors relevant to each jurisdiction are taken into account¹⁸ and the basic framework presented here is eventually adjusted to local priorities.

¹⁸ For instance, in countries where transmission auctions are expected to be attract significant competition, concerns with strategic manipulation may be of less importance and not be evaluated quantitatively. In countries where there is interest in allowing smaller companies to participate in

2.4 Mathematical formulation

This section presents the framework for simulating the CA, SDA & SA and thus investigating potential benefits of treating the exposure problem in multi-item transmission auctions.

The following nomenclature is used:

$n \in N$	Set of bidders participating in auction;
$j \in J$	Set of items in auction (concessions that include groups of transmission facilities);
$p(n) \in P(n)$	Set of packages in which bidder n is interested;
V^j	Reservation value ¹⁹ for each item, in \$.

The rest of the nomenclature will be presented opportunely.

It is worth mentioning that the models presented below are generally applicable to a broad range of industries where, as in the case of electricity transmission, reverse auctions are used to allocated items to the bidders requiring the least revenues to explore concessions or similar authorizations to perform a service.

2.4.1 Combinatorial auction

The protocol of combinatorial auction for transmission concessions to be used in this document corresponds to a sealed envelope auction. Simulations are made with and

auctions, special attention may be given to investigating the issue of entry deterrence. Other countries without a credible history of organizing auctions may prefer to use protocols with low complexity in the design and implementation. And so on.

¹⁹ In auction theory, the term is used in reference to a value that establishes a threshold over (or under) which no bid is accepted. Bidders can only present bids inferior or equal to this bid cap. Reservation values may be determined on the basis of opportunity costs of not allocating the package to any bidder in the auction (and allowing an incumbent to explore the concession). This interpretation will be used in the case studies

without a Vickrey-Clarke-Groves (VCG) pricing rule [37]-[38], which is described further in this text.

Before the auction, each agent privately determines a set of packages of his interest, valuing applicable complementarities and considering any budget constraints that would prevent him to acquire some combinations simultaneously. At the onset of the CA, each agent delivers a sealed envelope with as many package bids as wants. Each bid contains the RR to explore all items in the package, $B_{p(n)}$ in \$, and a vector of binary parameters of length $|J|$, $\{a^1_{p(n)}, \dots, a^j_{p(n)}, \dots, a^{|J|}_{p(n)}\}$. The binary parameter $a^j_{p(n)}$ equals 1 if item j pertains to package $p(n)$, and 0 otherwise.

The auctioneer selects the winning packages (and winning bidders) to minimize total RRs, and assures that package bids are treated indivisibly. If item j is not allocated to any bidder, the auctioneer penalizes the objective function by V_j , since the reservation value is an opportunity cost. The winner selection problem to be solved by the auctioneer is the following MILP:

$Z^* = \min\{[\sum_{n \in N} \sum_{p(n) \in P(n)} B_{p(n)} \cdot u_{p(n)}] + [\sum_{j \in J} V^j \cdot \psi_j]\}$	(1)
subject to	
$\psi_j + \sum_{n \in N} \sum_{p(n) \in P(n)} a^j_{p(n)} \cdot u_{p(n)} = 1$; $\forall j \in J$ (2)
$\sum_{p(n) \in P(n)} u_{p(n)} \leq 1$; $\forall n \in N$ (3)

where:

$u_{p(n)}$ Binary decision variable that equals 1 if package $p(n)$ was accepted and 0 otherwise;

ψ_j Binary decision variable that equals 1 if no package bid containing item j was accepted.

Z^* Is the value of the objective function at the optimal solution of problem (1)-(3), [\$].

Problem (1)-(3) is a direct adaptation of [31] to transmission auctions with the features of interest for this chapter. Objective function (1) minimizes the sum of RRs of selected packages, plus opportunity costs of items not allocated to any bidder. Constr. (2) ensures that, for each item: either it pertains to one and only one winning package; or the opportunity cost associated with it must be computed in the objective function.

Constraint (3) ensures that at most one package is accepted per bidder²⁰. This requires that sealed envelopes contain bids for all packages in which a bidder is interested, which requires high efforts from the bidder to evaluate ex ante (i.e., before the auction) all possible packages of his interest and imposes relatively high (transaction) costs for participating in the auction. These high costs may be a reason for preferring a SDA to a CA, since in the former the ex-ante exhaustive specification of packages is not required, and it is substituted by efforts carried out within the auction.

Once winners are selected, the auctioneer needs to determine the RR that each winner will effectively receive for exploring the concessions in the package. Two pricing rules will be simulated: a first-price rule and a second-price rule.

Under the first-price rule, the bidder simply receives for the package the value $B_{p(n)}$ that he has bid in the auction [23],[37].

The VCG approach is used for the second-price rule. Under it, each winner is allowed to capture additional revenues (a premium) on top of its bid. The premium corresponds to the bidder's contribution to the auctioneer's objective function – i.e., the decrement in total RR of accepted bids, with respect to a reference situation in which the winner would not have taken part in the auction. Decoupling the effective remuneration of the bidder from its own bid incentivizes him to reveal its best estimate (private value) of the RR to explore the concession, reducing incentives for strategic behavior [37],[38]. This theoretical result is not the only reason for using the VCG pricing rule in this chapter: using this pricing rule facilitates the comparison of the CA results to those obtained for the SDA.

²⁰ There are CA designs where more than one package can be accepted per bidder, but this is considered in the protocol used in the analyses of document.

The VCG pricing rule used here for simulations of the CA is a direct adaptation of [23],[31],[37]. Once the winner selection problem is solved and the set of winning bidders, $w \in W$, is known, the auctioneer uses the algorithm (a)-(b) below to determine the actual RR awarded to each winning bidder w :

- a) Solve the following modified version of problem (1)-(3), with the objective function $Z^{*,-w}$, where it is assumed that the winning bidder w does not participate in the auction:

$Z^{*,-w} = \min\{[\sum_{n \in (N \setminus \{w\})} \sum_{p(n) \in P(n)} B_{p(n)} \cdot u_{p(n)}] + [\sum_{m \in M} V^j \cdot \psi_j]\}$	(4)
--	-------

subject to

$\psi_j + \sum_{n \in (N \setminus \{w\})} \sum_{p(n) \in P(n)} a_{p(n)}^j \cdot u_{p(n)} = 1$; $\forall j \in J$	(5)
$\sum_{p(n) \in P(n)} u_{p(n)} \leq 1$; $\forall n \in \{N \setminus \{w\}\}$	(6)

- b) The actual RR awarded to winner w under the VCG rule, B_w^{VCG} , is then given by the sum of the bid declared as a winner as a result of the *winner selection problem*, which we denote as B_{p_w} , and the difference ($Z^{*,-w} - Z^*$). Thus, we have $B_w^{VCG} = B_{p_w} + (Z^{*,-w} - Z^*)$.

2.4.2 Simultaneous descending auction

The SDA is an iterative protocol, in which bidders are not required to present bids for packages at the beginning of the auction. In the SDA, the participants bid for individual items auctioned simultaneously within an iterative process.

In each round k of the SDA, agents bid for individual items auctioned simultaneously. The monetary value of the bid of agent n for item j in round k is denoted by $b_{n,k}^j$. The rules of the SDA protocol used in the analyses of this document are:

- In each round k , the auctioneer determines: (i) an upper bound to the bids that can be presented for each item j ; (ii) the *standing low bidder* (SLB) for each item – the bidder holding the *standing low bid* (the lowest RR), $U^{j,k}$, for the item at the end of the previous round. In the first round, $U^{j,k=1} = V^j$ for all j .
- To become the SLB for item j , a bidder must present a bid inferior to the standing low bid by at least a factor $(1-\eta)$. The auctioneer enforces this rule, for all items, as follows: (i) for all bidders but the SLB, he sets the upper limit $(1-\eta) \cdot U^{j,k}$; (ii) for the SLB, the upper bid limit is $U^{j,k}$, meaning that the SLB for any given item can simply maintain its previous bid for this item as a valid one, if he wishes.
- The bid any bidder n may present for an item j in a given round will only be valid if it is lower than or equal to the most competitive bid he presented in any of the previous rounds of the auction – i.e., $b_{n,k}^j \leq b^{HIST,j}_{n,k}$, where the superscript *HIST* denotes the most competitive historical bid so far.
- Allowing bid withdrawals can enhance the flexibility of bidders to reallocate resources and change the choice of the package $p(n)$ implicitly considered while bidding. But allowing bid withdrawals can also slow down the *convergence* process of a SDA (due to the withdrawal of a bid leading to opportunities for several bidders to reorganize their implicitly considered packages, which can then require extra rounds in an auction) and lead to opportunities to strategic behavior. It is important to notice, however, that forbidding bid withdrawals will not necessarily lead to a SDA finishing in a smaller number of rounds, as the results of one of the case studies will show. Considering all these phenomena, three different bid withdrawal subprotocols are simulated in this chapter: (i) unpenalized bid withdrawals are allowed; (ii) bid withdrawals are allowed but penalized; and (iii) bid withdrawals are forbidden, meaning that all bids presented by any given

bidder are binding. Formulations will be presented for this three subprotocols.

- The *winner selection problem* solved by the auctioneer in each iteration of the SDA is trivial: he must simply select the lowest bid for each item, provided that these bids are lower than the upper bound. The auctioneer keeps the rounds going until he verifies that, in any round, the identity of the SLB and the lowest bid for each item have not changed with respect to their values in the previous iteration. The auction then finishes and the SLBs at that point are declared winners. The revenues they will actually receive for the concessions correspond to the standing lows bids at the termination of the auction.

These resemble a subset of usual rules for simultaneous ascending auctions in the telecommunications industry²¹ [32],[33], adapted for the simulations of SDAs in transmission.

The reader will notice that, in the SDA, the complexity of *implicitly* selecting packages is placed on the bidders. Since they know the upper limits to their bids for each item j and round k , each bidder n privately determines the bids $b_{n,k}^j$ it will present to seek to implicitly acquire a package of items of its interest. Ignoring strategic behavior, bidders implicitly select bids to maximize their expected profits (difference between the total RR of all items they expect to win and their private estimates of the actual *costs* to explore these concessions).

In this chapter, we employ a formulation of the optimization problem solved by each bidder considering a somewhat naïve behavior of a risk-averse bidder. Bidders implicitly choose the package at which there are bidding and the monetary values of the

²¹ *Activity rules* are common in the telecommunications industry [32],[33], and aim at ensuring that the iterative auction ends after a reasonable number of rounds [33]. As the number of rounds is not a concern for the simulations of this chapter, due to exclusive focus on the treatment of the exposure problem, activity rules aren't considered here. The rounds number can be a concern in real SDAs for transmission, and activity rules may need to be imposed.

bids for each item to maximize their profit considering the constraints corresponding to the auction rules, but ignoring: estimates of the probability of being able to win each item at the end of the auction (which is consistent with the assumption of risk-averse agents, also employed in the modelling of bidder behavior under other protocols); and opportunities for strategic behavior. This naïve model suffices for the discussions of this chapter²².

The optimization problem to be solved by each bidder n at each round k if *bid withdrawals are allowed* is:

$L_n^{*,k} = \max\{\sum_{p(n) \in P(n)} l_{p(n)} \cdot v_{p(n)}\}$	(7)
subject to	
$\sum_{p(n) \in P(n)} a_{p(n)}^j \cdot v_{p(n)} \leq 1$; $\forall j \in J$ (8)
$\sum_{p(n) \in P(n)} v_{p(n)} \leq 1$	(9)

²² To understand why this model suffices for the purposes of this chapter, the reader may consider the following, which is a summarized version of the discussion of Section 2.3.4. The SDA protocol can be more prone to strategic manipulation by bidders, regarding signaling and punishing as means to implement collusive strategies. While this and other possible disadvantages of the SDA are not explored in this chapter, we also do not consider alternatives to enhance the performance of SDAs via increased sophistication in the design of protocols. As already mentioned, the main goal of this work is to present protocols that can be used to mitigate the exposure problem in the transmission auctions, thus offering insight on the potential for their use in this industry. The extensive simulation of *all* relevant phenomena that may need to be considered by regulators while choosing among alternative protocols to treat the exposure problem exceeds the objectives of this chapter. In fact, regulators in different jurisdictions may perceive different drivers for this choice. For instance, in some cases where there is structural concentration in the industry, the choice may be more strongly driven by the need to hinder collusive behavior; while other countries with lacking institutional experience with auctions may prioritize simpler designs to decrease the probability of errors. Seeking to simulate all phenomena relevant to the choice of auction protocols would thus not only be an impractical exercise, but could also masque the main message of this chapter, which refers to the potential benefits of treating the exposure problems in jurisdictions that employ auctions for transmission concessions. We hope that the numerical investigation of these benefits evokes discussions in these jurisdictions, ultimately leading to benefits to transcos and grid users.

$b_{n,k}^j \leq \{U^{j,k} \cdot [1 - \eta \cdot (1 - \sigma_{n,k}^j)]\} \cdot [\sum_{p(n) \in P(n)} a_{p(n)}^j \cdot v_{p(n)}]$ $+ [U^{j,k} + \Lambda] \cdot \{1 - \sum_{p(n) \in P(n)} a_{p(n)}^j \cdot v_{p(n)}\} \quad ; \forall j \in J$	(10)
$b_{n,k}^j \geq [U^{j,k} + \Lambda] \cdot \{1 - \sum_{p(n) \in P(n)} a_{p(n)}^j \cdot v_{p(n)}\} \quad ; \forall j \in J$	(11)
$b_{n,k}^j \leq b_{n,k}^{HIST,j} \cdot [\sum_{p(n) \in P(n)} a_{p(n)}^j \cdot v_{p(n)}] +$ $[U^{j,k} + \Lambda] \cdot \{1 - \sum_{p(n) \in P(n)} a_{p(n)}^j \cdot v_{p(n)}\} \quad ; \forall j \in J$	(12)
$l_{p(n)} = [\sum_{p(n) \in P(n)} a_{p(n)}^j \cdot b_{n,it}^j] - \theta_{p(n)} \quad ; \forall p(n) \in P(n)$	(13)

where:

$v_{p(n)}$ Binary decision variable that equals 1 if package $p(n)$ is implicitly considered by the bidder while forming the bids and 0 otherwise;

$l_{p(n)}$ Continuous decision variable that represents the profit the winner will capture for package $p(n)$ if its current bids are accepted, [\$];

$\theta_{p(n)}$ Parameter that indicates the private estimate of the actual costs the bidder expects to incur to explore the transmission concessions of package $p(n)$; [\$].

$\sigma_{n,k}^j$ Binary parameter that equals 1 if bidder n is the SLB for item j at the end of round $k-1$ and 0 otherwise;

$L_n^{*,k}$ Optimum value of the objective function, corresponding to the profit of bidder n at round k if its bids are accepted, [\$];

Λ Parameter corresponding to a small positive value²³.

All other parameters were explained before, including the vector $\{a_{p(n)}^1, \dots, a_{p(n)}^j, \dots, a_{p(n)}^{|J|}\}$. Here, this vector is not informed to the auctioneer by the bidder – this vector is only considered by the bidder himself, when he is privately choosing the package of

²³ The value of the parameter Λ only needs to be large enough for a commercial optimization solver to perceive the numerical difference between $U^{j,k}$ and $U^{j,k} + \Lambda$, there being no conceptual trade-offs relevant for its definition. For all simulations of Section 2.5, $\Lambda = 1$ was used.

items that he will implicitly consider while forming bids for individual items in the SDA.

Objective function (7) refers to the maximization of the bidder's profit. Eq. (8) ensures that, while forming its bids, the bidder considers that an item can pertain to at most one package whose complementarities are implicitly considered. Eq. (9) can be interpreted as a budget constraint: all possible item combinations that form relevant packages for bidder n are assumed to be included in $P(n)$, and those not included in $P(n)$ are infeasible due to exceeding the bidder's budget.

Eq. (10) enforces the auction rules that: (i) for a bid for item j to be valid, it must be below $U^{j,k}$ by a factor of at least η if the bidder is not the SLB at the end of the previous round; (ii) the SLB can simply keep its standing low bid if he wishes. Eqs. (10) and (11) jointly ensure that, if the package $p(n)$ that is implicitly considered by the bidder does not include item j , he will present a bid for this item that exceeds the upper bound by Λ – this will be an invalid bid, which the auctioneer will simply interpret as bidder n not presenting a valid bid for j .

Eq. (12) enforces the rule that a bidder can only present a valid bid for an item j that is lower than or equal to the most competitive bid he presented in any of the previous rounds.

Constraint (13) computes the profit the bidder will capture for package $p(n)$ if its current package bid is accepted.

Problem (7)-(13) is non-linear due to the product of decision variables $l_{p(n)} \cdot v_{p(n)}$ in (7). To linearize it and transform it in a MILP, it suffices to substitute this product by an auxiliary continuous decision variable $\zeta_{p(n)}$ in (7) and use the following disjunctive constraints to ensure that $\zeta_{p(n)} = l_{p(n)} \cdot v_{p(n)}$:

$D_{p(n)}^L \cdot (1 - v_{p(n)}) \leq \zeta_{p(n)} - l_{p(n)} \leq D_{p(n)}^U \cdot (1 - v_{p(n)})$	$;\forall p(n) \in P(n)$	(14)
$D_{p(n)}^L \cdot v_{p(n)} \leq \zeta_{p(n)} \leq D_{p(n)}^U \cdot v_{p(n)}$	$;\forall p(n) \in P(n)$	(15)

where the value of the disjunctive constants $D_{p(n)}^L$ and $D_{p(n)}^U$ is determined offline, with help of the following equations:

$D_{p(n)}^L = \min\{-aux, aux\}$	(16)
$D_{p(n)}^U = \max\{-aux, aux\}$	(17)
$aux = a_{p(n)}^j \cdot \min\{U^{j,k} \cdot [1 - \eta \cdot (1 - \sigma_{n,k}^j)]; b_{n,k}^{HIST,j}\} - \theta_{p(n)}$	(18)

Eq. (7)-(15) above correspond to the bid formation problem to be solved by the bidder when bid withdrawals are allowed.

If bid withdrawals are forbidden, the SLB for item j at the end of a round will always need to present a valid bid for the item in the next round. As the SLB will only be displaced if another bidder presents a more competitive bid and becomes the SLB in the following round, the bid formation problem to be solved when *bid withdrawals are not allowed* can be obtained by simply adding constraint (19) to problem (1)-(15).

$\sum_{p(n) \in P(n)} a_{p(n)}^j \cdot v_{p(n)} \geq \sigma_{n,k}^j$	$;\forall j \in J$	(19)
--	--------------------	--------

By constraint (19), if the bidder was the SLB at the end of the previous round ($\sigma_{n,k}^j=1$), it will need to present a valid bid for item j in the current round.

Consider now the *subprotocol where bid withdrawals are allowed, but penalized*. We assume the penalty a bidder must pay for withdrawing a bid for item j is the maximum between: (i) zero; and (ii) the difference between the withdrawn bid $b_{n,k}^j$ and the final bid for item j at the end of the auction. This penalty corresponds to the monetary amount by which the withdrawal affects the auction results (a conceptual definition introduced in [33]). Right after a bid withdrawal for item j , the auctioneer sets $U^{j,k} = V^j$. Yet, the rule obliging bidders to present bids at most equal to their best historical bids for the item ($b_{n,k}^{HIST,j}$) will effectively limit feasible bids.

Under this rule, a bidder must only be concerned with the penalty for withdrawing a bid for item j until another bidder presents a more competitive bid for that item, since after that the value of the withdrawal penalty effectively becomes zero²⁴.

This feature is explored while defining the problem to be solved by bidders when withdrawals are allowed, but penalized. Assume that bidder n keeps track of the items j for which it is obliged to pay a non-zero withdrawal penalty. He will do that by defining, at the end of each round, a set $J_{n,PW}$ that contains all items for which he perceives *pending withdrawal penalties*. If the penalty that the bidder will pay for a withdrawal reaches zero in a later round, the bidder will remove item j from $J_{n,PW}$.

Considering this, we present the modifications of problem (7)-(15) required to define the bid formation problem under the protocol with penalized withdrawals: (i) the original objective function (7) must be *substituted* by Eq. (20) below; and (ii) constraints (21) & (22) must be added to the problem.

$L_n^{*,k} = \max\{[\sum_{p(n) \in P(n)} l_{p(n)} \cdot v_{p(n)}] - \sum_{j \in J} \tau_j \cdot \Gamma_j\}$	(20)
$\sum_{p(n) \in P(n)} a_{p(n)}^j \cdot v_{p(n)} \geq \sigma_{n,k}^j - \tau_j$	$;\forall j \in \{J \setminus J_{n,PW}\}$ (21)
$a \sum_{p(n) \in P(n)} a_{p(n)}^j \cdot v_{p(n)} = 1 - \tau_j$	$;\forall j \in J_{n,PW}$ (22)

In equations (20)-(22) above: the binary decision variable τ_j equals 1 if the bidder expects to pay a penalty due to bid withdrawal for item j in this round, 0 otherwise; and parameter Γ_j is the monetary value of the penalty the bidder expects to pay due to the bid withdrawal (calculated offline, based on the results of the previous round and the described penalty rules).

²⁴ After a more competitive bid than that withdrawn by n is presented, n is released of penalties even if the other bidder later also withdraws his bid, as the other bidder pays the difference between the final selling price and his bid.

Objective function (20) was modified by the inclusion of the withdrawal penalization. Constraint (21) ensures that, for items for which there is not currently a pending withdrawal penalty, the bidder will perceive a penalty starting from this round if it is the SLB for the item and decides to withdraw a bid – if $\sigma_{n,k}^j=1$, variable τ_j will be set to 1 if the bidder wishes to consider a package that does not include j while bidding.

Constraint (22) ensures that, if the bidder decides to present a bid in this round for an item for which *there is* a pending bid withdrawal, it will no longer be penalized for that.

Under all subprotocols, each item is allocated to the SLB at the end of the SDA. The RR he will receive for exploring the concession j will equal its last valid bid. The winning bids do not necessarily equal the bidders' private estimate of the costs incurred for exploring the concessions of the last package implicitly considered while forming bids. In fact, under the rules of the SDA, the winning bid for each item must only be lower than the most competitive bid presented by competitors during the auction. This offers insight on why the final auction prices obtained with the SDA can be similar to those obtained with a second-price rule. Yet, if competition is strong, there can be little differences between the closing prices and the private value of the bidders, as the examples will show²⁵.

It is worth noticing that the SDA protocols employed in this chapter do not guarantee optimization of total welfare (nor do they ensure a maximum level of suboptimality), even when unpenalized bid withdrawals are allowed. This becomes evident when one considers the rule limiting the bid of each bidder to his most competitive bid so far (i.e., $b_{n,k}^j \leq b^{HIST,j}_{n,k}$) and the fact that the parameter η must be positive for the auction to converge in a finite number of rounds. Some of the research on more sophisticated iterative protocols for auctions of multiple heterogeneous auctions mentioned in section II.D, however, is targeted towards the design of

²⁵ Also, if bid withdrawals are not allowed or are penalized, the bidder may be compelled to capture revenues lower than its private evaluation of the costs of the concessions, or prefer this to paying the corresponding penalties.

mechanisms that ensure that the allocation of items under an iterative auction protocol reproduces that of a sealed-bid VCG auction that leads to optimization of total welfare (see, for instance, [39]).

2.4.3 Sequential auction

The simulated SA consists of a sealed-envelope auction in which each individual item is auctioned sequentially, from $j=1$ to $j=|J|$. The *winner selection rule* is trivial: for each item, the bidder presenting the best bid (lowest RR) is the winner.

Bidder behavior is slightly more complex. For any item j in set J , bidder n does not consider the possibility of capturing complementarities with items $\{j+1, j+2, \dots |J|\}$ to be auctioned posteriorly, since he cannot be sure he will win them. But if a bidder already won any item $\{1, 2, \dots j-1\}$ in previous stages, he considers any relevant complementarities in the current stage while forming bids for j . This is the behavior of a risk-averse agent that assumes the probability of winning any items *in the future* is 0. Bidders are assumed not to bid strategically, presenting sealed envelopes with bids corresponding to their private value for the implicitly considered packages.

First-price and second-price rules are simulated for the SA. Under the first-price rule, the RR to be effectively paid to each winner simply correspond to the winning bid. The second-price rule is a simple Vickrey one [37]: the RR effectively allocated to each winner equals the second most competitive bid presented by competitors, since the difference between the first and the second most competitive bids is a proxy of the winner's contribution to the final auction results.

2.5 Case studies and discussion

In this section, the previously exposed auction protocols are applied to three case studies. The 1st case study, a small-scale auction, allows a thorough discussion of the auction protocol mechanics. The 2nd and 3rd cases (medium- and large-scale auctions),

illustrate the performance of protocols regarding the exposure problem and the potential benefits of their use in transmission auctions.

Case studies are built using realistic data on transmission concessions auctioned in Brazil. Impacts of complementarities on the RR of packages of items and each bidders' private valuation of these synergies are estimated, since these are not public data. Budgetary constraints were also estimated while determining the packages of interest of bidders. All monetary values presented here are annuities (annual revenue requisites, profits, surpluses, etc.). These can also be assumed to represent values of monetary quantities without qualitatively changing the results and conclusions.

For all case studies, the sum of the reservation values for all auctioned items are presented. A relevant auction performance indicator is the difference between the sum of the reservation values and the actual RR awarded to winners at the end of the auction – this metric is a proxy of the *grid users' surplus*²⁶. The difference between the actual RR awarded to winners and their private estimates of the costs incurred in the exploration of the concessions is another performance indicator, referred to as the *bidders' surplus*. The sum of the surpluses captured by grid users and bidders, termed the *total surplus*, is a proxy of the total monetary benefits captured by these entities.

2.5.1 Case study A: small-scale auction

This auction comprises 3 transmission concessions; and 3 bidders participate in the auction. Table 2.1 present features of the items, Table 2.2 shows the bidders' characteristics, and Table 2.3 presents detailed information on relevant package bids.

²⁶ If an item doesn't attract bids in the auction, the concession is explored by an incumbent utility receiving revenues equal to the reservation value.

Table 2.1. Features of Items (Transmission Concessions) of Case Study A

j	Relevant characteristics	V^j [k\$]
1	500/230 kV; 750 MVA; 1500 km; proximity to item 2	120,000
2	500 kV; 600 km; proximity to item 1; significant series compensation; proximity to existing assets of bidder 2	60,000
3	500/230 kV; 100 MVA; 500 km; significant series compensation; proximity to existing assets of bidder 2	77,500

Table 2.2. Features of Bidders of Case Study A

n	Relevant characteristics
1	Experienced transmission operator, captures high O&M synergies
2	Manufacturer, captures economies of scale w/ series compensation
3	New entrant, low capital costs, only interested if total RR $\geq 100 \cdot 10^6$ \$

Table 2.3. Relevant Packages for Case Study A

Bidder	Package	Items in package	Private value [k\$]	Complementarity mechanism
1	1	{1,3}	163,587.0	Economies of scope related to O&M
1	2	{1}	104,147.9	-
1	3	{3}	70,445.3	-
2	1	{2,3}	116,127.0	Econ. of scale w/ series compensation
2	2	{1}	104,200.0	-
2	3	{2}	50,531.3	-
2	4	{3}	70,266.0	-
3	1	{1,3}	167,984.5	Ec. scale allowing access to cheaper capital
3	2	{1,2}	149,648.5	Ec. scale allowing access to cheaper capital
3	3	{2,3}	118,611.0	Ec. scale, minimum token for new entrant
3	4	{1}	101,595.0	-

The auction protocols simulated in this first case study are: SA with first-price & with second-price (Vickrey) rule; CA with first-price & with second-price (VCG) rule; SDA with $\eta = 1\%$ and non-penalized bid withdrawals.

The results obtained are shown in Table 2.4.

Table 2.4. Summary of Results of Case Study A: Comparison of Performance of SA, CA and SDA Auction Protocols

Protocol	Auction protocol [-]	Sequential auction		Combinatorial auction		SDA (with withdrawal, $\eta = 1\%$)
	Pricing rule [-]	2 nd price	1 st price	2 nd price	1 st price	Not explicit
	Total reservation values [k\$]	257,500				
	Total awarded revenue requirements[k\$]	225,124	219,915	223,698	214,118	216,047
	Total private value for bidders [k\$]	219,915	219,915	214,118	214,118	214,118
	Total bidders' surplus [k\$]	5,210	0.0	9,580	0.0	1,929
	Total grid users' surplus [k\$]	32,376	37,586	33,802	43,382	41,453
	Total surplus [k\$]	37,586	37,586	43,382	43,382	43,382
	Number of rounds [-]	Sealed envelope (no rounds in auction)				22
	Bidders to which items $J=\{1,2,3\}$ are allocated [-]	{3,2,2}		{1,2,1}		{1,2,1}

The CA and the SDA led to identical total surpluses in case A. This is a result of items being allocated to the same bidders, which considered (explicitly in the CA, implicitly in SDA) the same packages at the optimal solution of the auction. The total surplus obtained for the CA and the SDA is higher (by ~15%) than that of the SA, indicating the superior performance of the former protocol in treating the exposure problem.

The allocation of the total surplus among bidders and grid users varies per auction protocol and pricing rule. For the CA and the SA, first-price rules allocate the entire total surplus to grid users, while bidders retain a parcel of it under second-price rules. We stress that first-price rules theoretically result in weaker incentives for agents

to present bids equal to private values [37], a feature not simulated here. Despite of leading to the same results of the CA regarding assignment of items to bidders, the SDA results in a total surplus allocation between bidders/grid users somewhere in between that of the CA with the first-price rule and the CA with VCG prices, as expected. The bidders' surplus under the SDA is numerically closer to that of the CA with first-prices than that of the CA with second-prices, which is partially attributable to the rule of the SDA that limits bids the most competitive historical bid so far.

The limitations of the *sequential auction* in treating the exposure problem are better understood by considering the bidding behavior for each of the items auctioned sequentially:

- 1) Each agent bids for the 1st item without knowing if it will be able to subsequently form a multi-item package with it. Thus, only bids considering item 1 *alone* were presented. This meant that item 1 was allocated to bidder 3, which has the lowest private value for item 1 alone.
- 2) Then, in the auction for the 2nd item, bidder 3 implicitly considered the possibility of completing his package #2. This allowed him to present a bid for item 2 equal to the difference between his private value for package #2 and the revenues he already captured with certainty for item 1, making his bid very competitive. Meanwhile, bidder 2 presented a bid implicitly considering package 3, which contains item 2 alone and was thus less competitive. Bidder 2 did not present a bid implicitly considering his package #1, which contains items {2,3}, since he is not sure of whether he will be able to acquire item 3 in the future. Item 2 was thus also allocated to bidder 3.
- 3) For the 3rd item, bidder 3 presented no bids, since he is not interested in acquiring all three items at once. The lowest bid was that of bidder 2 (with package #4: item 3 alone).

This example shows how the impossibility of the bidders being certain that they will have any multi-item packages integrally “won” or “lost” can lead to suboptimal

auction results, illustrating the limited performance of the sequential auction protocol in treating the exposure problem.

It is trivial to apply the simulation framework of section III for the *combinatorial auction* to understand the solution to the winner selection problem in this case. The more complex task of understanding the VCG pricing rule is aided by Table 2.5: its last columns show the solution of the pricing sub-problems for winners 1 and 2; while its last row shows that the VCG price to which each winner is entitled simply equals the sum of his bid and his incremental contribution to the auction results.

Table 2.5. Results of Winner Selection Problem and of Pricing Sub-problems for the CA Protocol with the VCG Pricing Rule

		Type of problem within CA with VCG pricing		
		Winner selection	Pricing sub-problem	
			Bidder 1	Bidder 2
Selected package of bidder n	$n=1$	1	<i>Out of pricing prob.</i>	3
	$n=2$	3	1	<i>Out of pricing prob.</i>
	$n=3$	None	4	2
Total RR [k\$]		214,118	217,722	220,094
Bidder's contribution to auction results [k\$]		-	3,604 (=217,722-214,118)	5,976 (=217,722-214,118)
VCG price for bidder [k\$]		-	167,191 (=163,587+3,604)	56,507 (=50,531+5,976)

Figure 2.1 offers insight on the convergence of the *simultaneous descending auction*, showing that competition leads to decreasing standing low bids for each item as rounds pass.

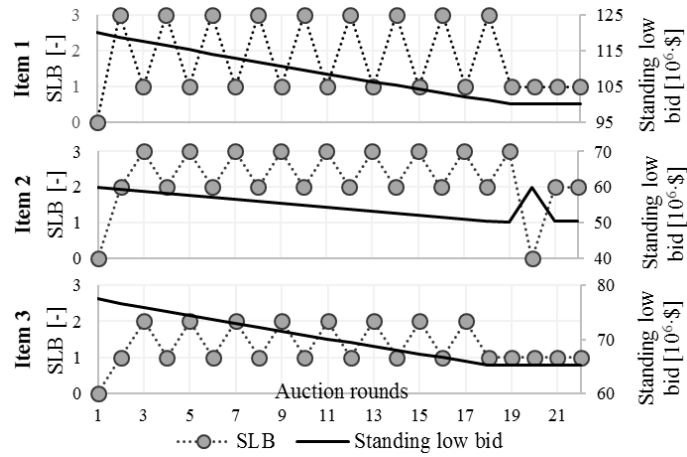

Figure 2.1. Evolution of solution of SDA as a function of auction rounds.

Figure 1 reveals why, in the SDA, bidders capture surpluses lower than those attained with the CA with VCG prices:

- Bidder 3 stops bidding towards rounds 18 or 19, when the standing low bids minus the decrement factor $\eta = 1\%$ result in achievable RRs below private values of any of his packages.
- After agent 3 gives up, items 1 and 3 are allocated to bidder 1, which now implicitly considers his package #1. At that time, the bids for both items together correspond to total RR of 165.5 M\$. As this is higher than bidder 1's private value for package #1, 163.6 M\$, he captures a surplus 1.9 M\$ – a lower surplus than he got under the CA with VCG prices (his surplus under the CA with VCG prices was of 3.6 M\$).
- Bidder 2 captures item 2 after bidder 3 drops out. But the highest bid bidder 2 could offer was limited to the most competitive of his previous bids, which led to him to capture a RR of 50.58 M\$. As his private value for item 2 was of 50.53 M\$, the resulting surplus for this item was of 0.05 M\$ – lower than what bidder 2 got under the CA with VCG prices.

2.5.2 Case study B: mid-sized auction

This auction includes 11 items, which are marked as items 1 to 11 in Figure 2.2. There are 14 bidders competing in the auction. The total number of package bids is 79, and some bidders consider as much as 12 packages. Full input data is not presented here due to space constraints.

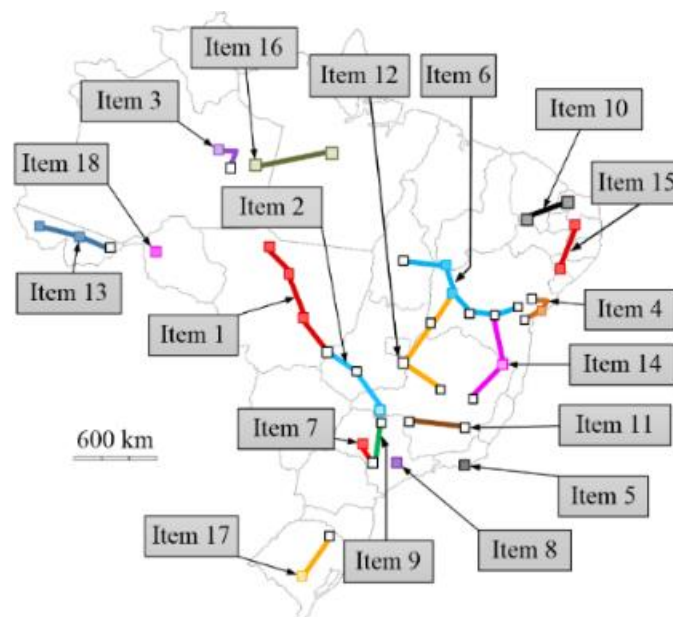

Figure 2.2: Items in auction from case studies B (1 to 11) and C (1 to 18): graphical depiction

Table 2.6 shows results of simulations of the same protocols of the previous case study, and also of SDA subprotocols with *forbidden* or *penalized* bid withdrawals.

Table 2.6. Summary of Results of Case Study B: Comparison of Performance of SA, CA and SDA Auction Protocols

Protocol	Auction protocol [-]	Sequential auction		Combinatorial auction		SDA (with $\eta = 1\%$)		
	Pricing rule [-]	2 nd price	1 st price	2 nd price	1 st price	Not explicit		
	Bid withdrawal [-]	<i>Does not apply</i>				Allowed	Forbidden	Penalized
Total reservation values [k\$]	322,870							
Total awarded RR [k\$]	275,984	241,851	230,023	227,083	229,280	223,131		
Total private value for bidders [k\$]	246,451	241,851	227,083	227,083	227,082	227,083		
Total bidders' surplus [k\$]	29,532	0	2,941	0	2,198	-3,952		
Total grid users' surplus [k\$]	46,887	81,019	92,847	95,787	93,590	99,739		
Total surplus [k\$]	76,419	81,019	95,787	95,787	95,787	95,787		
Number of rounds [-]	Sealed envelope (no rounds in auction)				44	55		
Bidders winning $J=\{1..11\}$ [-]	{2,1,4,12,4,11,12,1,13,10,4}			{2,2,4,12,4,6,12,6,13,2,4}			{2,2,4,12,4,6,12,6,13,2,4}	

As in section 2.5.1, the CA and the SDA performed better than the SA in treating the exposure problem, both leading to total surpluses higher than those of the SA.

The winning bidders and packages explicitly or implicitly considered are identical in the CA and the SDA with allowed bid withdrawals, leading to the same total surpluses, despite of different allocations among grid users and bidders.

Yet, Table 2.6 shows that the performance of the SDA can vary depending on the bid withdrawal subprotocol²⁷, at least for the naïve model of bidder behavior used here. Negative bidders' surpluses are seen for the subprotocols with *forbidden* or *penalized* withdrawal. These are explained by bidders being obliged to stick to unattractive bids (forbidden withdrawal) or preferring this to paying withdrawal penalties. Such negative surpluses may not be seen under more sophisticated models of

²⁷ In case study B, SDA subprotocols with forbidden & penalized bid withdrawals have led to the same results, but this needs not be the case for other examples.

bidder behavior, and forbidding/penalizing withdrawals seems to be a common approach in simultaneous ascending auctions in telecommunications [33]. But these results allude to the fact that, if bidders cannot freely withdraw bids (that is to say, if bid withdrawals are forbidden or penalized), the sophistication in their bidding behavior must increase if they are interested in capturing complementarities – and this should be considered while evaluating the use of SDA for transmission concessions.

Table 2.6 also indicates that the number of rounds for the *forbidden/penalized* withdrawal subprotocols was higher than that obtained with *unpenalized* withdrawals. In this case study, keeping competing for specific items, by presenting bids as rounds passed, was the preferred strategy of some bidders confronted with the perspective of having to stick to unattractive packages – they were seeking to form alternative packages. This particular result for the case study at hand illustrates that forbidding/penalizing withdrawals does not necessarily lead to an SDA finishing in fewer rounds. The use of activity rules might have changed this outcome.

Before proceeding to case study C, we briefly discuss the trade-off involved in the choice of the parameter η , with aid of additional simulations of the SDA subprotocol where bid withdrawals are allowed. To offer insight on the trade-off involved in the choice of η , we simulated applications of this protocol with the bid decrement factor set to 1.25% and 1.5%. The results are shown in Table 2.7, which also reproduces the results for the same subprotocol with $\eta = 1.0\%$, to facilitate the comparison.

Table 2.7. Summary of Results of Case Study B: Additional Simulations of the SDA Protocols with Unpenalized Withdrawals, Varying the Value of Parameter η

Prot.	Auction protocol [-]	SDA with allowed bid withdrawals		
	Value of η [-]	1.0%	1.25%	1.5%
Total reservation values [k\$]		322,870		
Total awarded RR [k\$]		229,280	229,807	229,752
Total private value for bidders [k\$]		227,082	227,082	227,566
Total bidders' surplus [k\$]		2,198	2,724	2,186
Total grid users' surplus [k\$]		93,590	93,063	93,118
Total surplus [k\$]		95,787	98,787	95,304
Number of rounds [-]		44	35	30
Bidders winning $J=\{1..11\}$ [-]		{2,2,4,12,4,6,12,6,13,2,4}		{2,2,4,12, 2 ,6,12,6,13, 10 , 2 }

These results illustrate the trade-offs involved in the choice of this parameter, as explained below.

Higher values of η can result in the SDA ending after a smaller number of rounds: only 35 and 30 rounds for η set respectively to 1.25% and 1.5%, in comparison with the 44 rounds for $\eta = 1.0\%$. Higher values of η result in prices in the auction decreasing *faster* (i.e., in fewer rounds). The number of rounds is important in real-world applications, since an auction with too many rounds (long duration) results in higher costs of participation for the auctioneer and for the transcos.

But higher values of η can lead to less efficient SDA results, even if bid withdrawals are allowed. This is illustrated by the total surplus for $\eta = 1.5\%$ in Table 2.7 being lower than that obtained for other values of η . The reader will notice that the allocation of items to bidders for $\eta = 1.5\%$ changes with respect to that obtained with $\eta = 1.0\%$, which is the globally optimal allocation since it coincides with that of the CA protocol, as indicated in Table 2.6. This is due to the fact that a high value of η may oblige a transco to present a bid in a given round k that decreases his $b^{HIST}_{j,n,k}$ sufficiently to render some package choices infeasible or inefficient, from his private

point of view, in the next rounds. The fact that these packages become unattractive to the bidder can result in a less efficient final allocation of items at the end of the auction.

Table 2.7 also shows that, for this case study, the total surplus obtained with $\eta = 1.25\%$ is the same as for $\eta = 1.0\%$, though $\eta = 1.25\%$ leads to a higher parcel of the total surplus captured by bidders. This illustrates that different values of η can lead to changes in the allocation of the total surplus among bidders and grid users. The result is also explained by the fact that a higher η may oblige a transco to present a bid that decreases his $b^{HIST}_{j,n,k}$ sufficiently to render some packages unattractive for him in the subsequent rounds. In this example with $\eta = 1.25\%$, the bidders that perceived packages as unattractive due to this phenomenon were those that would ultimately “give up” on the packages before the end of the auction. The higher value of η led these competitors to stop bidding earlier in the auction, resulting in the ultimate auction winners capturing a higher parcel of the total surplus.

The choice of $\eta = 1.0\%$ for the simulations of case studies A and C of this chapter was made heuristically. This value was deemed to lead to a manageable number of interactions even for the large-scale case study C (where the number of rounds exceeded 100, already a high number for real-world auctions), while allowing the illustration of relevant features of the SDA protocol with aid of realistic examples.

2.5.3 Case study C: large-scale auction

The auction of case C includes 18 transmission concessions and 17 bidders, with a total number of package bids of 142. It was built by extending the dimensions of case B (number of items, bidders and even the number of relevant package bids for each bidder). All 18 concessions of case study C have been depicted in Figure 2.2.

Table 2.8. summarizes the simulation results.

Table 2.8. Summary of Results of Case Study C: Comparison of Performance of SA, CA and SDA Auction Protocols

Prot.	Auction protocol [-]	Sequential auction		Combinatorial auction		SDA (with withdrawal, $\eta = 1\%$)
	Pricing rule [-]	2 nd price	1 st price	2 nd price	1 st price	Not explicit
	(A) Total reservation bids [k\$]	451,170				
	(B) Total awarded RR [k\$]	372,792	331,878	334,073	308,315	326,586
	(C) Reservation value of unawarded items [k\$]	24,750	24,750	0	0	12,820
	(D) Total private value for bidders [k\$]	331,878	331,878	308,315	308,315	300,348
	(E)=(B-D) Total bidders' surplus [k\$]	40,914	0	25,758	0	26,238
	(F)=(A-B-C) Total grid users' surplus [k\$]	53,629	94,542	117,097	142,855	111,764
	(E+F) Total surplus [k\$]	94,542	94,542	142,855	142,855	138,002
	Number of rounds [-]	Sealed envelope (no rounds in auction)				116
	Bidders winning items $J=\{1\dots 18\}$ [-]	{2,1,2,4,12,4,11,12,1,13,10,4, 0 ,15, 0 ,5,9,7}		{1,1,3,15,2,4,17,17,17,15,10,10,3,4,15,3,17,3}		{2,2,15,10, 0 ,1,17,17,17,13,2,1,10,10, 0 ,15,17,15}

With the total surplus as the performance indicator, we conclude that the CA outperforms the SA & the SDA, regarding treatment of the exposure problem, while the SDA outperforms the SA.

There are items not allocated to any bidder under the SA and under the SDA: these are indicated by 0 in bold typeface in the last row of Table 2.8. This is due to the inability of bidders to form some of the multi-item packages under these protocols, hinting at limitations regarding treatment of the exposure problem. Yet, the reservation values of items not allocated under the SDA are lower than that of the SA, again hinting at a better performance of the former protocol. The exact SDA results obtained here are affected by the naïve bidder behavior model. Though it is expected that the CA outperforms the SDA in practice regarding the treatment of the exposure problem, one should notice that the SDA has other advantages not investigated in this chapter, such as

its ability to reduce bidder exposure to the winner’s curse [32] due to the revelation of information during the interactive auction.

Before proceeding to the conclusions, a few words on the computational time required for solving the MILP problems associated with the CA protocol are in order, since this is a large example. The total solution time for the *winner selection* subproblem was of 6.2s, and the average solution time for the *pricing* subproblems under the VCG pricing approaches was of 5.8s (under the VCG approach, 7 pricing subproblems are solved). The commercial solver FICO Xpress™ Vr. 7.9 was used in all simulations, which were performed in a personal computer with processor Intel Core™ i7-6500 CPU@ 2.50/ 2.60 GHz, 16 GB RAM, and a 64-bit operating system. These relatively fast solution times are explained by the fact that, even for a problem that may be characterized as a large-scale one in the context of transmission auctions, the dimensions of the corresponding MILP are not problematic for available commercial-grade optimization solvers. For instance, the full *winner selection* subproblem is a MILP with solely 35 constraints – the reader may refer to equations (2) and (3) and recall that $J = 18$ and $N = 17$ in this large-scale case study. The number of structural columns and of non-zero elements in the problem matrix are also relatively low.

2.6 Conclusions

The analyses suggest there can be potential benefits in using the CA or SDA protocols in jurisdictions where several transmission concessions (authorizations to implement/operate facilities) are auctioned each year, and where the agents to whom concessions are awarded are basically selected via price-based competition. This is the case, for instance, in Latin American countries such as Brazil, Chile, Colombia, and Peru. The use of such protocols, in substitution to SA protocols prevailing in these jurisdictions, can ease the consideration of complementarities between sets of transmission facilities by auction participants, resulting in benefits to the bidders

themselves and to the grid users paying charges to cover the revenues to which transmission auction winners are entitled for exploring the concession.

The simulation framework of section III was used for case studies built with realistic data, and for all of them the CA and SDA protocols outperformed the SA regarding treatment of the exposure problem. Though the mathematical framework used in this chapter does not account for strategic bidding behavior and, in the case of the SDA, does not consider the modification of bids due to perceived probabilities of winning items, it sufficed to verify the following theoretical results: (i) the SA is outperformed by the CA and the SDA in its ability to treat the exposure problem; and (ii) the CA outperforms the SDA with respect to the same criterion. We stress that the analyses of the chapter purposefully focus on the exposure problem and that we do not assess other features important in real applications, including the ability to deal with the winner's curse, prevent barriers to new entrants and smaller agents, or hinder collusion.

The analyses also hint at the potential impacts on revenues to be collected from transmission grid users if second-price rules (Vickrey pricing for SA, VCG for the CA) are employed, after the solution of the winner selection problem, to determine the RRs to which auction winners will be effectively entitled. Impacts on RR are of more than 10% in some cases. Though second-price rules present important advantages over first-price rules, such as incentivizing agents to present bids equal to their actual private estimates of the RRs to explore the transmission concessions, regulators and policymaker may in practice encounter some practical resistance to implementing them, due to such impacts on RR.

As previously mentioned, the simulation framework used in this chapter does not include any models of strategic behavior by transcos bidding in the auctions, even though strategic behavior is a relevant concern for regulators choosing among auction protocols for real-world applications. Prior technical work on auctions for multi-item auctions of heterogeneous items focusing in other industries [22]-[23],[33], including references focusing on analyses of results of actual implementations of simultaneous ascending auctions in the telecommunications sector, suggest that the various protocols

investigated in this chapter display different levels of exposure to strategic manipulation. Iterative auctions protocols (structurally similar to the SDA investigated in this chapter) may be particularly prone to strategic bidder behavior, for instance due to increased opportunities of signaling and punishing as means of implementing collusive strategies [43]. Though CA protocols are theoretically less prone to strategic manipulation [31], there is less empirical evidence on their use, especially in the context of capital-intensive industries (such as electricity transmission and telecommunications), where investment capabilities and technical specialization limit the number of potential bidders. Hence, quantitative investigations of the impacts of strategic manipulation on outcomes of different auction protocols for multi-item auctions of transmission concessions may also be relevant to aid evaluations from regulators, in complement to the analyses of this chapter. This can constitute a relevant topic for future work.

In fact, the range of attributes of different auction protocols to be considered by regulators and policymakers facing this choice extends beyond the topic of possibilities to treat the exposure problem and strategic behavior. Other items, such as deterrence of entry of smaller players or implementation complexity, are also expected to be relevant for regulators.

Finally, we stress that this chapter deals exclusively with auctions in which a planning authority determines the set of transmission facilities best fit to meet a predefined systemic need, and uses an auction to select the agent that requires the lowest revenues to implement and operate these facilities. This approach to transmission auctions is extensively used in the Latin American countries mentioned in the Introduction, and competitive process that closely resemble it have also been used in jurisdictions in the northern hemisphere [30]. Yet, there are other possible auction models for the transmission segment – such as the *needs-based* approach [29], in which the planning authority identifies a systemic need but lets agents propose both the nature of the technical solution to meet the need and the revenues required to implement this solution. Under this alternative approach, which stimulates innovation by allowing

bidders to propose technical solutions to meet systemic needs, selecting the agents to which the authorization to develop the transmission solution will be awarded involves the evaluation of factors other than revenue requirements. Though this chapter did not investigate possible benefits of using auction protocols that allow dealing with the exposure problem under such alternative approach to auctions in the transmission segment, the topic merits attention and may represent a relevant object for future work – and one that requires further development of the simulation framework employed here.

It is worth mentioning that combinatorial auctions for transmission assets could be used as a tool to select, among various candidate transmission facilities of an expansion plan that are “offered” in the auction, those that should be part of the final expansion plan. This approach combines auction theory with transmission expansion planning, by considering various candidate facilities as items in an auction and using a winner selection function takes full account of the dynamics of power system expansion and operation costs. Not all of the candidates offered as items in the auction will be ultimately built – the winner selection function will take care of determining which candidates are ultimately built. The resulting auction protocol may be too complex to use in practice, but applying it offers some interesting insight on how auctions can be used to reveal information that is useful for expansion planning, and how planning can benefit from acquiring more accurate information on costs (and implementation times). Appendix A of this thesis presents an example of this.

Other possible future extensions of the work are presented in chapter 5, section 5.1.2.

3 TRANSMISSION EXPANSION PLANNING UNDER CONSIDERATION OF UNCERTAINTIES IN FACILITY IMPLEMENTATION TIMES

This chapter deals with the topic of transmission expansion planning under explicit consideration of uncertainties in the time required for implementing the facilities (to which we refer as *implementation times*) and, consequently, in their commercial operations date (COD). The focus is on proposing a methodology with these objectives and evaluating whether there will be impacts of explicitly considering such uncertainties.

The chapter is organized as follows:

- Section 3.1 deepens the motivation presented in the introductory chapter of this document and presents the objectives of this chapter;
- Section 3.2 contains a review of the technical literature and presents the novelties of the work;
- Section 3.3 characterizes the problem at hand, introducing concepts relevant for understanding the proposed mathematical formulation;
- Section 3.4 presents the proposed mathematical formulation to solve the problem at hand;
- Section 3.5 presents case studies and discusses their results;
- Section 3.6 contains the main conclusions of the work;

Possible future extensions of the work are presented in section 5.2.2 (chapter 5).

The nomenclature used in the mathematical formulation of this chapter should be taken independently of the nomenclature used in the other chapters of this document.

3.1 Motivation and objectives

Section 1.1.2 of this document provided evidence of how delays in the implementation of transmission facilities have been increasing in frequency and severity in several countries. It also discussed how some jurisdictions, in response to the problem of implementation delays, have been conducting efforts to implement processes in which determinative transmission expansion plans are prepared with as much antecedence as possible with respect to the date in which the facilities would need to commence operation, in order to increase the time available for the implementation of transmission facilities.

The approach proposed in this section aims at taking a step further in this direction. We propose a methodology for transmission planning that aims at explicitly considering the uncertainty in facility *implementation times* (and thus implicitly considering implementation delays), in order to ensure that the *decisions* about *what* transmission facilities to build and *when to initiate their implementation* are made in order to obtain an expansion plan that ensures that the system is optimally adjusted to (or “protected from”) these uncertainties in implementation times and, therefore, delays. This goes beyond the practice of simply advance the planning process in time as much as possible – it also involves adjusting the transmission expansion decisions, regarding the *nature* and *implementation schedule* of new facilities.

In the remainder of this chapter, the expression *facility implementation time* (or just *implementation time*) is used in reference to the time span between *the instant in which the beginning of the implementation of a facility happens* and *the instant in which the facility enters commercial operations*. Here, we consider that the events that take place between these two milestones include the licensing, engineering, procurement, construction and commissioning of the transmission facilities.

The objective of this chapter is to propose and employ a transmission expansion planning approach is to determine, besides the nature of the facilities in the expansion

plan, the optimal instant to initiate the implementation of each facility in the expansion plan, when there are uncertainties in implementation times.

The expression *implementation start date* is used in reference to the date at which the implementation of the facilities is scheduled to start. Determining this date is a decision of the transmission expansion planner.

3.2 Literature review and novelties of the approach

Reviews on transmission expansion planning, including both recent [24],[44] and classical [45] surveys, indicate that a methodology, including a mathematical formulation, for explicitly taking uncertainties in implementation times of transmission facilities while determining expansion plans is not available in the technical literature. Recent references focusing on minimax optimization approaches to the transmission expansion planning problem (see, for instance, [46]-[47]) do not tackle the issue of uncertainty in implementation times either.

Such a methodology represents the main technical contribution of this chapter.

3.3 Problem characterization

As already mentioned, the objective of this chapter is to obtain a transmission expansion planning approach to determine the nature and the optimal instant to initiate the implementation of reinforcements, given that there are uncertainties in implementation times

The two conceptual tasks required for a planning approach such as that described in the previous paragraphs are the following:

- Determine, with the best efforts of the planner, probability distributions²⁸ of implementation times of all transmission facilities that will be considered as

²⁸ It is also possible to conduct the efforts using other mathematical representations of uncertainties, such as extreme scenarios. This document focuses on the situation in which probability distributions are used

candidates for a transmission expansion plan. In jurisdictions where there are significant historical records of delays, this can be achieved via statistical treatment of historical data. In jurisdictions where such historical records are not available, this can be made via expert judgment – for instance, by consulting specialized EPC companies, institutions with expertise in social-environmental impacts of transmission facilities, etc. It is important to notice that there is always the possibility that the system planner may not be able to acquire perfect information on the probability distribution of delays, especially in contexts where there are information asymmetries with respect to the agents that will actually implement the transmission facilities (a situation that is not uncommon in jurisdictions where planning is centralized, but implementation is made via transmission concessionaires selected by means of auctions). But planning efforts should be conducted with aid of the best information available.

- With the probability distributions of implementation times at hand, build an optimal transmission expansion plan that optimizes a certain merit index (for instance, minimizes the expected value of the sum of the expansion costs and costs of operating the system), while considering that, even though the planner can determine the implementation start dates of all facilities in the plan, there is uncertainty regarding the date at each facility will actually commence operations – that is to say, the *actual COD* cannot be known deterministically as a result of setting the implementation start date, as it depends on the implementation times of the candidate facilities, which are uncertain parameters. This may lead to changes about the nature of the

for the representation of the uncertainties. Problem formulations other than that presented in the following sections may be required if other mathematical representations of uncertainties in implementation delays are used – for instance, if extreme scenarios are used, one may resort to robust optimization or minimization of the maximum regret. We opt for the representation of uncertainties in implementation times via probability distributions to take advantage of the historical data available in Brazil, whose statistical treatment can be used to estimate the such distributions, as exemplified in Appendix A.

facilities to be included in the plan (i.e., which of the candidates will enter the solution of the problem) and their implementation start dates.

The first task, of building a mathematical representation of the probability of delays by determining probability distributions, will depend on the information available in each jurisdiction. In a jurisdiction with a large enough historical records of implementation of facilities, it may suffice to build an empirical discrete probability distribution considering the past experience with implementation of transmission facilities with certain technical characteristics and implemented in geographical regions with a certain profile (regarding difficulties in environmental licensing, interference with indigenous peoples, subject to climatic events that may delay construction works, etc.), and then assume that this empirical discrete probability distribution is the best estimate of that which would apply for candidates facilities with similar profiles. Appendix B provides an example of how to do that. As already mentioned, expert judgment may be required in jurisdictions with less significant historical records.

The second task requires an adjusted planning methodology and formulation of the optimization problem of transmission system expansion, which is the main technical contribution of this chapter. This is presented in the following section.

3.4 Methodology and mathematical formulation

3.4.1 Starting with the problem without uncertainties in implementation times

Before presenting the mathematical formulation of the optimization problem of transmission expansion planning under consideration of uncertainty in implementation times, one may consider a reference formulation of the transmission expansion problem *without* considering these uncertainties. This will facilitate the understanding of the reader about the changes required to explicitly consider this class of uncertainties in the formulation.

For this reason, this section begins with the presentation of a reference mathematical formulation of the transmission expansion problem *without* considering uncertainties in implementation times. This is a two-stage, multi-period transmission expansion planning problem. The reference formulation considered in this work is presented in the following:

$\min \left\{ \sum_{t \in T} u^t \cdot \left[\sum_{j \in J_{DD}} b_j \cdot \left(\sum_{\{t \in T t \leq t\}} l_{j,t} \right) \right] + \right. \\ \left. \sum_{t \in T} u^t \cdot \left\{ \sum_{s_\sigma \in S_\sigma} p_{s_\sigma,t} \cdot \left[\left(\sum_{k \in K} \gamma_{k,s_\sigma,t} \cdot h_t \cdot c_{k,s_\sigma,t} \right) + \right. \right. \right. \\ \left. \left. \left(\sum_{i \in I} \sigma_{i,s_\sigma,t} \cdot h_t \cdot c_{LSH,i,t} \right) \right] \right\} \right\}$	(23)
---	------

subject to

$\sum_{t \in T} l_{j,t} \leq 1$	$;\forall j \in J_{DD}$	(24)
$\theta_{iREF,s_\sigma,t} = 0$	$;\forall i, s_\sigma \in S_\sigma, t \in T$	(25)
$\left(\sum_{\{k \in K BUS(k)=i\}} \gamma_{k,s_\sigma,t} \right) + \left(\sum_{\{j \in J BTO(j)=i\}} \varphi_{j,s_\sigma,t} \right) =$ $\left(\sum_{\{j \in J BFR(j)=i\}} \varphi_{j,s_\sigma,t} \right) + (d_{i,s_\sigma,t} - \sigma_{i,s_\sigma,t})$	$;\forall i \in I, s_\sigma \in S_\sigma, t \in T$	(26)
$\sigma_{i,s_\sigma,t} \leq d_{i,s_\sigma,t}$	$;\forall i \in I, s_\sigma \in S_\sigma, t \in T$	(27)
$\underline{g}_{k,s_\sigma,t} \leq \gamma_{k,s_\sigma,t} \leq \bar{g}_{k,s_\sigma,t}$	$;\forall k \in K_t, s_\sigma \in S_\sigma, t \in T$	(28)
$\varphi_{j,s_\sigma,t} = y_j \cdot (\theta_{BFR(j),s_\sigma,t} - \theta_{BTO(j),s_\sigma,t})$	$;\forall j \in J_{EX,t}, s_\sigma \in S_\sigma, t \in T$	(29)
$\varphi_{j,s_\sigma,t} - y_j \cdot (\theta_{BFR(j),s_\sigma,t} - \theta_{BTO(j),s_\sigma,t}) \leq M_j \cdot \{1 - (\sum_{\{t \in T t \leq t\}} l_{j,t})\}$	$;\forall j \in J_{DD}, s_\sigma \in S_\sigma, t \in T$	(30)
$-M_j \cdot \{1 - (\sum_{\{t \in T t \leq t\}} l_{j,t})\} \leq \varphi_{j,s_\sigma,t} - y_j \cdot (\theta_{BFR(j),s_\sigma,t} - \theta_{BTO(j),s_\sigma,t})$	$;\forall j \in J_{DD}, s_\sigma \in S_\sigma, t \in T$	(31)
$-\bar{f}_j \leq \varphi_{j,s_\sigma,t} \leq \bar{f}_j$	$;\forall j \in J_{EX}, s_\sigma \in S_\sigma, t \in T$	(32)
$\varphi_{j,s_\sigma,t} \leq \bar{f}_{j,s_\sigma,t} \cdot (\sum_{\{t \in T t \leq t\}} l_{j,t})$	$;\forall j \in J_{DD}, s_\sigma \in S_\sigma, t \in T$	(33)
$-\underline{f}_{j,s_\sigma,t} \cdot (\sum_{\{t \in T t \leq t\}} l_{j,t}) \leq \varphi_{j,s_\sigma,t}$	$;\forall j \in J_{DD}, s_\sigma \in S_\sigma, t \in T$	(34)

where:

$i \in I$	Set of buses;
$j \in J$	Set of transmission facilities (modelled as circuits in this problem);
$j \in J_{EX}$	Set of existing transmission facilities, $J_{EX} \subseteq J$;
$j \in J_{DD}$	Set of candidate transmission facilities, $J_{DD} \cap J_{EX} = \emptyset, J_{DD} \subseteq J$;
$k \in K$	Set of generators;
$s_\sigma \in S_\sigma$	Set of operation scenarios considered for problem solution (may include contingencies of transmission facilities and generators, different load conditions, different scenarios of availability of renewable generation, etc.);
$t, \hat{t} \in T$	Period of planning horizon (week, month, trimester, semester, year, etc.);
$\gamma_{k,s_\sigma,t}$	Continuous, non-negative decision variable: output of generator k in $\{s_\sigma, t\}$ [p.u.];
$\sigma_{i,s_\sigma,t}$	Continuous, non-negative decision variable: load shed in bus i in $\{s_\sigma, t\}$ [p.u.];
$\theta_{i,s_\sigma,t}$	Continuous decision variable, free in signal: voltage angle at bus i in $\{s_\sigma, t\}$ [rad];
$\varphi_{j,s_\sigma,t}$	Continuous decision variable, free in signal: active power flow through circuit j in $\{s_\sigma, t\}$ [p.u.];
$l_{j,t}$	Binary decision variable that equals 1 if the <i>target COD</i> of the facility j is set to period t ($l_{j,t} = 1$) and equals 0 otherwise;
i_{REF}	Parameter: index of angular reference bus;
h_t	Parameter: duration of period t in hours [hours]
u^t	Parameters: factor for getting present value of costs incurred in period t [-]
$p_{s_\sigma,t}$	Parameter: probability of operation scenario s_σ in period t [-];
$c_{LSH,i,t}$	Parameter: unitary costs of load shedding at bus i at period t [\$/p.u.];
$d_{i,s_\sigma,t}$	Parameter: demand at bus at bus i , in scenario s_σ and at period t [\$/p.u.];
γ_j	Parameter: inverse of reactance of circuit [p.u.]

\bar{f}_j	Parameter: maximum power flow through circuit j [p.u.];
b_j	Parameter: annual cost of transmission facility j (including annuity corresponding to capex recovery and remuneration, operational expenditures and any other relevant annual costs) [\$];
$BTO(j)$	Parameter: receiver bus of transmission facility j [-]
$BFR(j)$	Parameter: emitter bus of transmission facility j [-]
M_j	Parameter: disjunctive constant for disjunctive constraint of flow through circuit, in p.u., calculated as $y_j \cdot DLTHMX$, where $DLTHMX$ is the maximum difference of angles between any two buses in system;
$c_{k,s_\sigma,t}$	Parameter: variable production costs of generator k in period t [\$/p.u.];
$\bar{g}_{k,s_\sigma,t}$	Parameter: maximum output of generator k in period t and operation scenario s_σ [p.u.];
$\underline{g}_{k,s_\sigma,t}$	Parameter: minimum output of generator k in period t and operation scenario s_σ [p.u.];
$BUS(k)$	Parameter: bus to which generator k connects.

In the previous formulation, the binary decision variable $l_{j,t}$ is used to determine whether facility j is included in the expansion plan (in this case $\sum_{t \in T} l_{j,t} = 1$) and, if it is included in the plan, to define the *target COD* of this facility (the target COD will be the instant that for which $l_{j,t} = 1$). As uncertainties in implementation times are not yet taken into account, meaning that implementation time spans are taken deterministically, defining the implementation start date of each facility included in the plan is trivial – this date merely corresponds to the *target COD* minus the implementation time span.

In the previous formulation, the objective function corresponds to the expected present value of all costs within the planning horizon (23). It is important to notice that an economically meaningful computation of the parcel of costs of new transmission facilities for the purposes of planning effort within a finite time horizon requires that the residual value of any candidate investment at the end of the horizon is computed and

deducted from the initial investment²⁹. In practical terms, this is implemented by calculating an annuity value that remunerates the investment within its operational lifetime, and considering the value of the annuity for each of the years in which a given project is operational³⁰. The net present value of the series of annuities at the year in which the investment decision is made will therefore correspond to difference between the initial investment and the residual value of the asset in the end of the horizon. The value of b_j captures this, as it includes annuity corresponding to capex recovery and remuneration, fixed operational expenses and any other costs related to making the physical facility available.

Constraint (24) merely states that each candidate facility may have at most one target COD in the optimal solution. That is to say, if this candidate is included in the plan, the planner must determine a single period as the target date in which the project will commence commercial operations.

Constraint (25) defines the voltage angle at the angular reference bus as 0 radians, while constraint (26) enforces the balance of active power in each bus.

Constraint (27) establishes upper bounds on the load shedding at each bus, while constraint (28) establishes minimum and maximum output limits for each generator in the system.

Constraint (29) enforces the Second Kirchhoff Law (its version for the linearized power flow) for existing circuits, while constraints (30) and (31) do so for candidate circuits. Constraint (32) establishes limits on the power flow through circuits, while constraints (33) and (34) do the same for candidate circuits.

Some of the extensions of the reference formulation for the case without the modeling of uncertainties in commissioning delays are trivial. For instance, one may

²⁹ Neglecting this may lead to under-investment in the last years of the planning horizon, since the integrality of the investment costs of an asset whose useful lifetime exceeds the length of the horizon would be implicitly compared to the benefits within a short period of time – an incorrect approach.

³⁰ Conversely, if the problem is defined in a time discretization other than the yearly one, one shall use a “payment” adjusted to that time discretization, instead of an annuity.

establish minimum target commercial operation dates by forcing the variables $l_{j,t}$ to equal zero for a number of initial periods of the horizon. Other extensions, such as the incorporation of losses in the linearized problem with help of piecewise-linear functions, are slightly more complex, but also widely discussed and readily available in the literature. Changes in the objective function (for instance, to incorporate risk-adjusted metrics instead of expected values) are also attainable by applying known techniques. Thus, the formulation above is deemed as sufficiently representative for the purposes of this discussion.

Further references on mixed-integer linear programming approaches to the transmission expansion planning problem, which can be useful to provide a deeper understanding of the problem, and other aspects that may be worthy of investigation, include [48] and [49].

Having presented the reference formulation without the explicit modeling of delays and uncertainties in the target CODs, *the discussion may proceed to the proposed changes in the formulation* in order to model this class of phenomena.

3.4.2 Representation of scenarios of implementation times

The reader will recall that (discrete) probability distributions of implementation times for each candidate are assumed to be available – these may have been constructed with basis on statistical treatment of historical data, if such data is available, or with basis on estimates resulting from expert judgment.

We assume that the probability distribution of implementation times is independent of the instant chosen by the planner as the *implementation start date* – i.e., regardless of when the implementation starts, the probability distribution of implementation times is assumed to remain unchanged. This assumption tends to hold when the tasks that reveal challenges in implementation of facilities, such as the performing detailed geological surveys (which can reveal engineering challenges) or the

obtaining of social-environmental licensing (which can reveal challenges in avoidance of mitigation of social-environmental impacts), are executed only after the decision to start the implementation of the facilities is made. Though this may not always be the case, it corresponds to the situation verified in many jurisdictions, including Brazil and other Latin American countries [28], as well as in many jurisdictions in the USA and Canada [30].

Considering the assumed independence with respect to the implementation start date, the first step in the planning process will be to build a sample of implementation time scenarios for each candidate transmission facility. Let S_d be the sample of implementation time scenarios, and $s_d \in S_d$ represent each scenario in this sample. For each scenario s_d , one can use the discrete probability distribution to obtain the values of implementation times, in number of periods (months, trimesters, semesters, etc.), for each candidate facility $j \in J_{DD}$ in the system. Let $\delta_{s_d}^j$ be the value of the implementation time, in number of periods, sampled for facility j in scenario s_d . A probability p_{s_d} is associated to each scenario s_d .

The sample of scenarios is illustrated in Table 3.1.

Table 3.1. Illustration of sample of implementation times, $\delta_{s_d}^j \forall j \in J_{DD}$, in number of periods

Implementation times $\delta_{s_d}^j$ [number of periods]		Implementation time scenario					
		1	2	...	s_d	...	$ S_d $
Candidate facility	1	7	6	...	5	...	10
	⋮
	j	6	3	...	$\delta_{s_d}^j$...	5
	⋮
	$ J_{DD} $	8	11	...	10	...	9

This representation is flexible enough to accommodate any kind of statistical dependence assumed for the implementation times or each transmission facility. For instance, if the implementation times of facilities 1 and 2 are perfectly and positively correlated, we may have $\delta_{s_d}^{j=1} = a_a + b_m \cdot \delta_{s_d}^{j=2}$ for all implementation time scenarios s_d , where a_a and b_m are respectively an additive and a multiplicative factor.

If a discrete probability distribution is considered for the purposes of sampling the implementation times, the planner will always know what is the minimum and the maximum value that the variable $\delta_{s_d}^j$ may assume. Let this maximum and minimum value be $\delta_{s_d}^{min}$ and $\delta_{s_d}^{max}$, respectively and the set T_d be defined as:

$T_d = \{\delta_{s_d}^{min}, \delta_{s_d}^{min} + 1, \dots, \delta_{s_d}^{max} - 1, \delta_{s_d}^{max}\}$	(35)
---	--------

For the sake of conciseness of notation, the elements of T_d will be denoted simply by $t_d \in T_d$.

In order to define parameters that can be usefully incorporated in the mixed-integer linear program (MILP) of transmission system expansion optimization under explicit modeling of uncertainties in the facility implementation times, we further define the binary parameters z_{j,s_d,t_d} .

The parameter z_{j,s_d,t_d} will equal 1 if the value of the implementation time, expressed in number of periods, sampled for facility j in scenario s_d , is $\delta_{s_d}^j = t_d$; and will equal 0 for all other values of t_d for that facility j and scenario s_d . This can be represented graphically as in Figure 3.1.

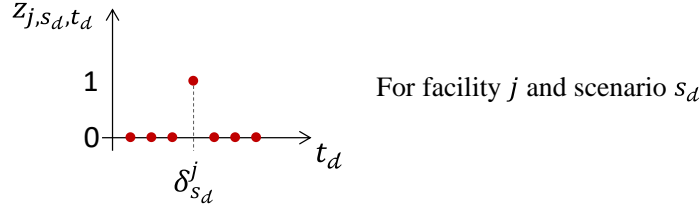

Figure 3.1: Illustration of definition of binary parameter z_{j,s_d,t_d}

3.4.3 Mathematical formulation of the problem considering uncertainties in facility implementation times

Given this probabilistic representation of the implementation times, the multi-period transmission expansion problem can be redefined, to account for the fact that the actual COD of the facilities equals the *implementation start date* set by the planner plus the uncertain duration of the *implementation time*, as follows:

$\min \left\{ \sum_{t \in T} u^t \cdot \left\{ \sum_{s_d \in S_d} p_{s_d} \cdot \left[\sum_{j \in J_{DD}} b_j \cdot \left(\sum_{\{t \in T, t_d \in T_d t+t_d \leq t\}} \zeta_{j,t} \cdot z_{j,s_d,t_d} \right) \right] \right\} + \right. \\ \left. \sum_{t \in T} u^t \cdot \left\{ \sum_{s_d \in S_d} p_{s_d} \cdot \left\{ \sum_{s_\sigma \in S_\sigma} p_{s_\sigma,t} \cdot \left[\left(\sum_{k \in K} \gamma_{k,s_d,s_\sigma,t} \cdot h_t \cdot c_{k,s_\sigma,t} \right) + \right. \right. \right. \right. \right. \\ \left. \left. \left. \left. \left(\sum_{i \in I} \sigma_{i,s_d,s_\sigma,t} \cdot h_t \cdot c_{LSH,i,t} \right) \right] \right\} \right\} \right\}$	(36)
--	------

subject to

$\sum_{t \in T} \zeta_{j,t} \leq 1 \quad ; \forall j \in J_{DD}$	(37)
$\theta_{iREF,s_d,s_\sigma,t} = 0 \quad ; \forall s_d \in S_d, s_\sigma \in S_\sigma, t \in T$	(38)
$\left(\sum_{\{k \in K BUS(k)=i\}} \gamma_{k,s_d,s_\sigma,t} \right) + \left(\sum_{\{j \in J BTO(j)=i\}} \varphi_{j,s_d,s_\sigma,t} \right) = \\ \left(\sum_{\{j \in J BFR(j)=i\}} \varphi_{j,s_d,s_\sigma,t} \right) + (d_{i,s_\sigma,t} - \sigma_{i,s_d,s_\sigma,t}) \\ ; \forall i \in I, s_d \in S_d, s_\sigma \in S_\sigma, t \in T$	(39)
$\sigma_{i,s_d,s_\sigma,t} \leq d_{i,s_\sigma,t} \quad ; \forall i \in I, s_d \in S_d, s_\sigma \in S_\sigma, t \in T$	(40)
$\underline{g}_{k,s_\sigma,t} \leq \gamma_{k,s_d,s_\sigma,t} \leq \overline{g}_{k,s_\sigma,t} \quad ; \forall k \in K_t, s_d \in S_d, s_\sigma \in S_\sigma, t \in T$	(41)
$\varphi_{j,s_d,s_\sigma,t} = y_j \cdot (\theta_{BFR(j),s_d,s_\sigma,t} - \theta_{BTO(j),s_d,s_\sigma,t}) \\ ; \forall j \in J_{EX,t}, s_d \in S_d, s_\sigma \in S_\sigma, t \in T$	(42)

$\varphi_{j,s_d,s_\sigma,t} - \gamma_j \cdot (\theta_{BFR(j),s_d,s_\sigma,t} - \theta_{BTO(j),s_d,s_\sigma,t}) \leq$ $M_j \cdot \{1 - (\sum_{\{t \in T, t_d \in T_d t+t_d \leq t\}} \zeta_{j,t} \cdot z_{j,s_d,t_d})\}$ $; \forall j \in J_{DD}, s_d \in S_d, s_\sigma \in S_\sigma, t \in T$	(43)
$-M_j \cdot \{1 - (\sum_{\{t \in T, t_d \in T_d t+t_d \leq t\}} \zeta_{j,t} \cdot z_{j,s_d,t_d})\} \leq$ $\varphi_{j,s_d,s_\sigma,t} - \gamma_j \cdot (\theta_{BFR(j),s_d,s_\sigma,t} - \theta_{BTO(j),s_d,s_\sigma,t})$ $; \forall j \in J_{DD}, s_d \in S_d, s_\sigma \in S_\sigma, t \in T$	(44)
$-\bar{f}_j \leq \varphi_{j,s_d,s_\sigma,t} \leq \bar{f}_j$ $; \forall j \in J_{EX}, s_d \in S_d, s_\sigma \in S_\sigma, t \in T$	(45)
$\varphi_{j,s_d,s_\sigma,t} \leq \bar{f}_{j,s_\sigma,t} \cdot (\sum_{\{t \in T, t_d \in T_d t+t_d \leq t\}} \zeta_{j,t} \cdot z_{j,s_d,t_d})$ $; \forall j \in J_{DD}, s_d \in S_d, s_\sigma \in S_\sigma, t \in T$	(46)
$-\bar{f}_{j,s_\sigma,t} \cdot (\sum_{\{t \in T, t_d \in T_d t+t_d \leq t\}} \zeta_{j,t} \cdot z_{j,s_d,t_d}) \leq \varphi_{j,s_d,s_\sigma,t}$ $; \forall j \in J_{DD}, s_d \in S_d, s_\sigma \in S_\sigma, t \in T$	(47)

where:

$\zeta_{j,t}$ Binary decision variable that equals 1 if the *implementation start date* of the facility j is set to period t ($l_{j,t} = 1$) and equals 0 otherwise.

Now, the planner decides on when the implementation of each candidate facility in the plan shall start, by determining the values of the binary decision variables $\zeta_{j,t}$. The actual COD of the facilities will depend on this decision variable $\zeta_{j,t}$ and on the uncertain implementation times, modelled via parameters z_{j,s_d,t_d} , as explained further in this section.

The reader will notice that, in the problem above, the transmission system expansion planner still defines at most a single implementation start time for each facility that enters the plan. This can be clearly seen by verifying that the decision variable $\zeta_{j,t}$, which equals 1 if the implementation start date of facility j is set to period t , does not vary according to the delay scenarios. Constraint (37) is conceptually analogous to that of the problem without the modelling of uncertainties regarding

implementation times, and states that at most one implementation start date can be defined for each candidate facility. Naturally, if a candidate facility j is not included in the plan at all, $\zeta_{j,t} = 0$ for all periods t .

However, the previous problem formulation ensures that, despite the fact that a single implementation start date is defined for each facility, the *actual COD*, after which the facility will effectively be operational and change system operation, depends on the sampled implementation times and the parameters that represent them mathematically, Z_{j,s_d,t_d} .

This becomes evident when one sees that the following summation is included in several constraints of the formulation, as well as on the objective function:

$\sum_{\{t \in T, t_d \in T_d t + t_d \leq t\}} \zeta_{j,t} \cdot Z_{j,s_d,t_d}$	(48)
--	--------

The reader will easily verify that the multiplication of the binary decision variable by the binary parameter Z_{j,s_d,t_d} in the innermost part of the summation, and the summation over all values $\{t \in T, t_d \in T_d | t + t_d \leq t\}$, result in a *displacement* of the actual COD due to the implementation time.

Consider, for instance, the case in which the implementation time sampled for a certain facility j in scenario s_d is of $\delta_{s_d}^j = 5$, and assume that, in the optimal solution of the problem, the implementation start date of facility j was set to period $t = 2$. In this situation:

- Binary decision variables: $\zeta_{j,t=2} = 1$, and $\zeta_{j,t \neq 2} = 0$;
- Binary parameter for implementation time scenario s_d : $Z_{j,s_d,t_d=5} = 1$, and $Z_{j,s_d,t_d \neq 5} = 0$;

The reader can verify, simply by substituting the values in the summation given in equation (48), that in scenario s_d the value of the summation is 0 for any periods until $t = 6$, and the value of the summation is 1 for all periods starting from $t = 7$. This means that, in scenario s_d , the facility will not be operational until $t = 6$ and will be

operational for all periods starting in $t = 7$. Recall that that the implementation start date was in this example was defined as $t = 2$.

Analogously, if in this same example the implementation time sampled for facility j in scenario s_d were of $\delta_{s_d}^j = 2$, the value of the summation would equal 0 for all periods until $t = 3$, and the value of the summation would be 1 for all periods starting in $t = 4$. This means that, in this other scenario s_d , the facility will not be operational until $t = 3$ and will be operational for all periods starting in $t = 4$, recalling that its implementation start time was defined as $t = 5$.

Since the summation appears in the disjunctive constraints (43), (44), (46) and (47), the facility is considered as operational for the purposes of the system operation sub-problem only in the periods defined by the displacement of the implementation start date by the implementation times. That is to say, for the purposes of the operation subproblem the facility is only operational starting from its actual COD, given by the sum of the implementation start date (deterministic decision) and the implementation time (uncertain parameter).

Likewise, since in the objective function the summation appears multiplying the annuity costs of the candidate transmission facilities, in each scenario s_d the computation of these costs only begins after the actual COD of the facilities. This modeling fits the regulatory framework of interest of this document: in a jurisdiction where a third party is responsible for implementing and operating the facility, and gets the authorized annual revenues for it only after the commencement of operations of the asset, the costs for consumers effectively start to incur only after the actual COD of the facilities³¹.

³¹ In certain cases, the utility may be allowed to adjust the annual revenues to recover any cost-overruns that were associated with the implementation delays, if some kind of economic-financial rebalancing of the concession is required. This would lead to an increase in the annuity b_j that is correlated with the occurrence of delays. This phenomenon is not modeled here, but it represents one of the possible future expansions of the work for further stages of the thesis.

The modifications of the formulation for the case when implementation delays are explicitly taken into account also include:

- The simulation of a total number of snapshots of the system, for the purposes of computing costs and ensuring compliance with operation constraints, that is given by the Cartesian product of the sets S_σ and S_d . This can significantly increase computational efforts, depending of the size of the sample S_d , $|S_d|$.
- The computation, in the objective function, of the expected costs not only over the scenarios $s_\sigma \in S_\sigma$, but also over the scenarios $s_d \in S_d$. Again, we use the expected value over the scenarios S_d in the objective function, but the formulation may be adapted to consider risk metrics.

3.5 Case study and discussion

3.5.1 Input data

The power system considered in the case study of this section is that represented schematically in Figure 3.2. It basically consists of a modified version of the 14-bus IEEE test system [50], to which several modifications were made.

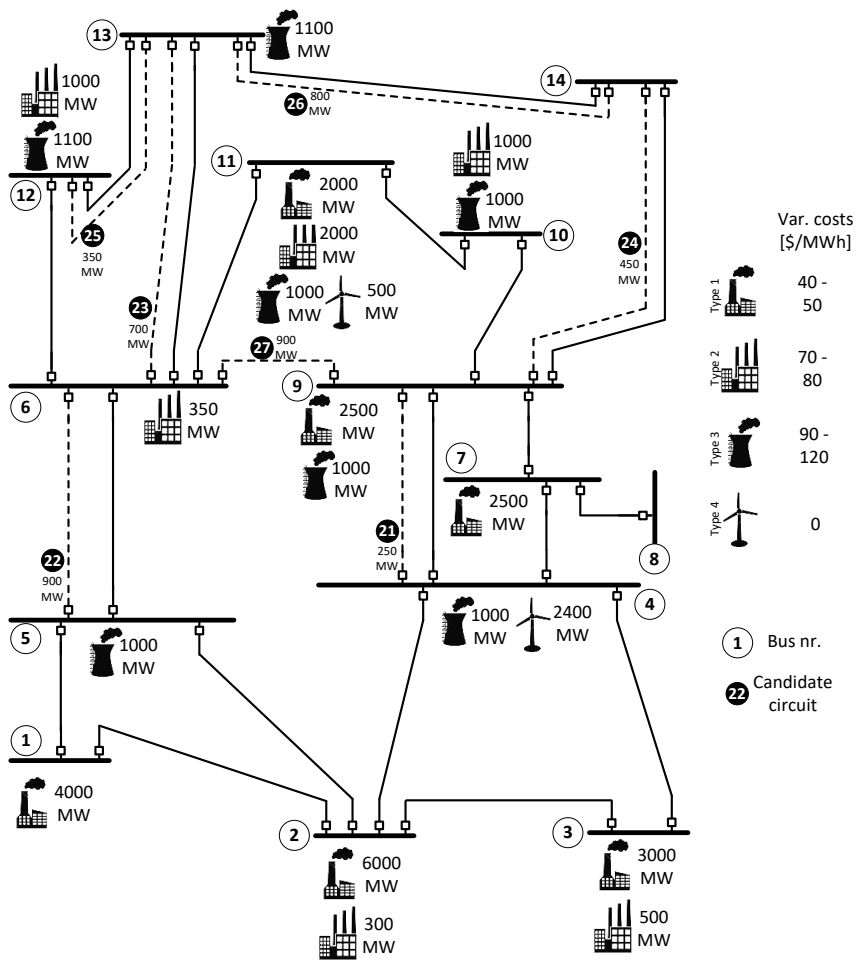

Figure 3.2: Schematic diagram of system for case study: network topology with candidates represented as dotted lines, installed generation capacity in last period of planning horizon

A general description of the modifications to the original 14-bus IEEE test system is presented in the following:

- The case was extended to a multi-period horizon, with 12 intervals each with 4 months of duration (i.e., four years). In each year, the second 4-month interval is that with the highest load (one can interpret it as the high-temperature season in the middle of the year), and the first one has the second highest load.
- The electric load of the system was increased significantly, and three operative scenarios $|S_\sigma| = 3$ were created for each 4-month interval

(roughly, these operation scenarios correspond to heavy loading, medium loading and light loading hours). Figure 3.3 depicts the load duration curve and the load per period (4-month interval) and operative scenario for the last year of the horizon). Load grows at a rate of approximately 5%/year.

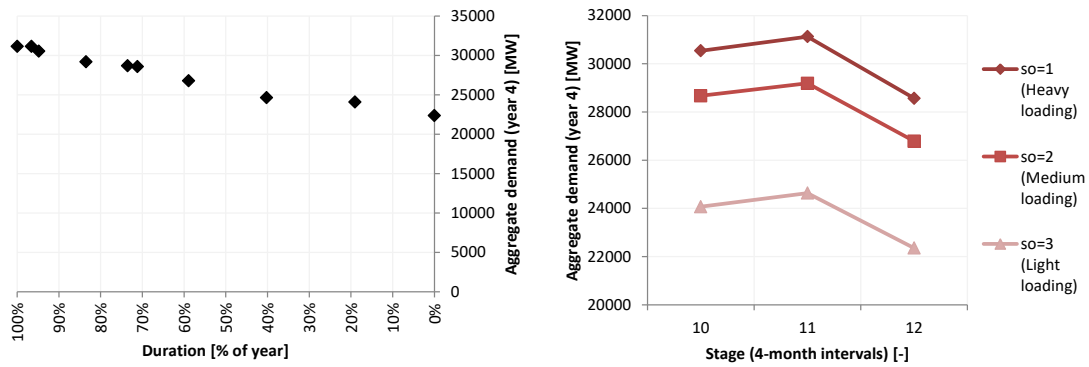

Figure 3.3: Load duration curve (left) and load per period and operative scenario (right) for 4th year of planning horizon

- The generation capacity in the system was increased significantly. Table 3.2 shows the main data for the generators in the system.

Table 3.2. Main data for generators in system

Generator #	Connect. bus	Type	Installed capacity [-]	Variable prod. costs [\$/MWh]	COD of generator (assumed to be certain) [period]
11200	11	Type 4 (renewable, variable gen.)	500 ^(a)	0	from beginning
4200	4	Type 4 (renewable, variable gen.)	2000 ^(a)	0	from beginning
13003	1	Type 1 (thermal, low costs)	4000	40	from beginning
43004	4	Type 1 (thermal, low costs)	2000	50	from beginning
23005	2	Type 1 (thermal, low costs)	5000	37.5	from beginning
33006	3	Type 1 (thermal, low costs)	3000	42.5	from beginning
93007	9	Type 1 (thermal, low costs)	2500	50	from beginning
113008	11	Type 1 (thermal, low costs)	2000	60	from beginning
123009	12	Type 2 (thermal, mid-merit)	1000	72.5	from beginning
103010	10	Type 2 (thermal, mid-merit)	1000	70	from beginning
113011	11	Type 2 (thermal, mid-merit)	2000	75	from beginning
73012	7	Type 2 (thermal, mid-merit)	2500	77.5	from beginning
53013	5	Type 3 (thermal, peaker)	1000	90	from beginning
93014	9	Type 3 (thermal, peaker)	1000	92.5	from beginning
103015	10	Type 3 (thermal, peaker)	1000	95	from beginning
113016	11	Type 3 (thermal, peaker)	750	100	from beginning
123017	12	Type 3 (thermal, peaker)	750	107.5	from beginning
133018	13	Type 3 (thermal, peaker)	500	120	10
23119	2	Type 1 (thermal, low costs)	1000	40	7
33120	3	Type 1 (thermal, low costs)	500	47.5	7
23121	2	Type 2 (thermal, mid-merit)	300	72.5	10
63122	6	Type 2 (thermal, mid-merit)	350	80	7
113123	11	Type 3 (thermal, peaker)	250	102.5	10

^(a) Available capacity of renewable generators depends on scenario.

- The impedances and line capacities from the original IEEE 14-bus systems were altered. Particularly, impedances were reduced significantly (with approximately the same reduction factor applied to all circuits, such that the ratio between different impedances was approximately kept) to avoid that the significant increase in system load in such a “small” system would lead to unrealistic values of angular differences between buses. Roughly speaking, other changes in impedances and capacities were made such that at least some transmission capacity additions would be needed from the middle of the planning horizon onwards. The existing circuits in the representation of the system are assumed to model bundles of physical circuits in the real system, and the capacity of these equivalent bundles of existing circuits is assumed to already be adjusted by security constraints. The main register data for circuits in the system are shown in Table 3.3.

Table 3.3. Register data for circuits in system

Circuit #	From bus	To Bus	"Annuity" per 4-month interval [\$] (for candidates only)	Resistance [%]	Reactance [%]	Capacity [MW]
1	1	2	-	0.01938	0.05917	600
2	1	5	-	0.05403	0.22304	2900
3	2	3	-	0.04699	0.19797	500
4	2	4	-	0.05811	0.17632	2850
5	2	5	-	0.05695	0.17388	3700
6	3	4	-	0.06701	0.17103	3250
7	4	5	-	0.01335	0.04211	4150
8	4	7	-	0.0434775	0.0980046	3050
9	4	9	-	0.0866893	0.19541	2350
10	5	6	-	0.0659513	0.1486637	6450

Circuit #	From bus	To Bus	"Annuity" per 4-month interval [\$] (for candidates only)	Resistance [%]	Reactance [%]	Capacity [MW]
11	6	11	-	0.09498	0.1989	3500
12	6	12	-	0.12291	0.25581	1700
13	6	13	-	0.0729596	0.1436801	6800
14	7	8	-	0.00889	0.02004	1850
15	7	9	-	0.0401838	0.09058	2400
16	9	10	-	0.03181	0.0845	1300
17	9	14	-	0.136972	0.2913578	5800
18	10	11	-	0.08205	0.19207	800
19	12	13	-	0.253823	0.2296494	2350
20	13	14	-	0.17093	0.34802	550
21	4	7	1,293,875	0.530426	1.195656	250
22	5	6	24,395,353	0.4726512	1.0654233	900
23	6	13	18,495,422	0.70875	1.39575	700
24	9	14	20,050,825	1.7654167	3.7552778	450
25	12	13	14,189,241	1.70424	1.5419314	350
26	13	14	70,587,206	0.1175144	0.2392638	800
27	6	9	96,829,047	0.177514	0.4160363	900

Table 3.4 shows the discrete probability distribution of implementation times assumed for the candidate circuits 21-27.

Table 3.4. Assumed discrete probability distribution of implementation times

Candidate circuit #	Probability of implementation time for each t_d [p.u.]							Average implementation time [periods] (for informative purposes only)
	$t_d = 3$	$t_d = 4$	$t_d = 5$	$t_d = 6$	$t_d = 7$	$t_d = 8$	$t_d = 9$	
21	0	0	0.1	0.75	0.1	0.05	0	6.10
22	0.15	0.6	0.15	0.1	0	0	0	4.20
23	0	0	0.8	0.15	0.05	0	0	5.25
24	0	0	0.85	0.1	0.05	0	0	5.20
25	0	0	0.85	0.1	0.05	0	0	5.20
26	0	0.15	0.6	0.15	0.1	0	0	5.20
27	0	0	0.1	0.75	0.1	0.05	0	6.10

From the previous table, it is clear that only mild uncertainties in implementation times are considered in this case study:

- (a) The possible implementation times are assumed vary at most within 4 intervals of 4 months (i.e., within 4 periods or 480 days). This variation is below that which would correspond to the maximum delays mentioned in section 1.1.2 of this document.
- (b) The assumed probability distributions are reasonably skewed. But in each case the mode of the probability distribution has a high probability (at least of 60%).

The reason to assume probability distributions with such characteristics is to show that, even for these distributions with “mild” uncertainties, the decisions of the expansion plan can be significantly altered with respect to the case where only the most likely scenario of implementation delays is considered. This will be explored further in this section.

The implementation delays for each facility are assumed to be statistically independent variables for the purposes of sampling.

3.5.2 Results

The following table indicates the value of selected decision variables and the value of the objective function of the problem of transmission expansion planning under explicit consideration of uncertainty in facility implementation times, for different sizes of the sample of scenarios of implementation delays, $|S_d|$.

Table 3.5. Case study results: expansion decisions as function of sample size

Item		Size of sample of scenarios of implementation times $ S_d $ [-]						
		$1^{(a)}$	20	50	100	200	400	500
Implementation start date for each candidate facility [-]	21	4	6	4	4	5	4	4
	22	3	1	2	2	2	2	2
	23	2	1	1	1	1	1	1
	24	6	4	5	4	4	4	4
	25	3	1	2	2	2	2	2
	26	-	-	-	-	-	-	-
	27	-	-	-	-	-	-	-
Value of objective function or value of component of the obj. func. [\$ billion]	Trans. exp.	0.297	0.385	0.348	0.364	0.363	0.365	0.366
	Operations	34.37	34.37	34.37	34.37	34.38	34.37	34.37
	Load shed.	0.000	0.000	0.027	0.011	0.011	0.014	0.014
	Total (objective function)	34.67	34.75	34.75	34.75	34.75	34.75	34.75
Solution time [s]		0.1	101.8	539.6	551.4	3201.6	26257.4	82331.7

(a) No uncertainty regarding implementation times was represented: the implementation time in this case with only one scenario was assumed to equal the mode of the probability distribution for each facility.

The reader should keep in mind that, since the monetary results of the previous table are shown in \$ billion, differences in the first decimal digit correspond to hundreds of millions of \$ and differences in the second decimal digit correspond to tenths of

millions of \$. Also, the relevant cost components here are the costs of congestion (including load shedding and redispatch) and the costs of expansion of the transmission system. There is a significant parcel of the costs of the operation costs in the objective function that represent “basis” operation costs, or the parcel of dispatch “unaffected” by congestion – in an intuitive explanation, the transmission expansion planning decisions affect only the costs imposed by the transmission system (congestion effects, including load shedding, and infrastructure availability costs), and therefore the parcel of the objective function that depends on them is relatively small.

Table 3.5 shows that the *implementation start dates* in the situations when uncertainties are taken into account can differ significantly from those obtained if the planner would consider that the implementation time of each facility is deterministic and defined by the mode (or the expected value rounded to an integer value) of the probability distribution. Section 3.6 will deepen this discussion.

Having presented these results, the discussion proceeds to detailed results obtained for the simulation with a sample of implementation time scenarios of size 500. The reader is invited to consider the composition of the objective function for each implementation time scenario in the following figures, noticing that both in Figure 3.4 and in Figure 3.5 the horizontal axis³² refers exclusively to scenarios of implementation times – i.e., the values depicted in these figures are averages over scenarios of operation.

³² The scenarios were sampled randomly, but for the purposes of constructing Figure 3.4 and Figure 3.5 the scenarios were ordered from that with the lowest total costs to these with the highest total costs.

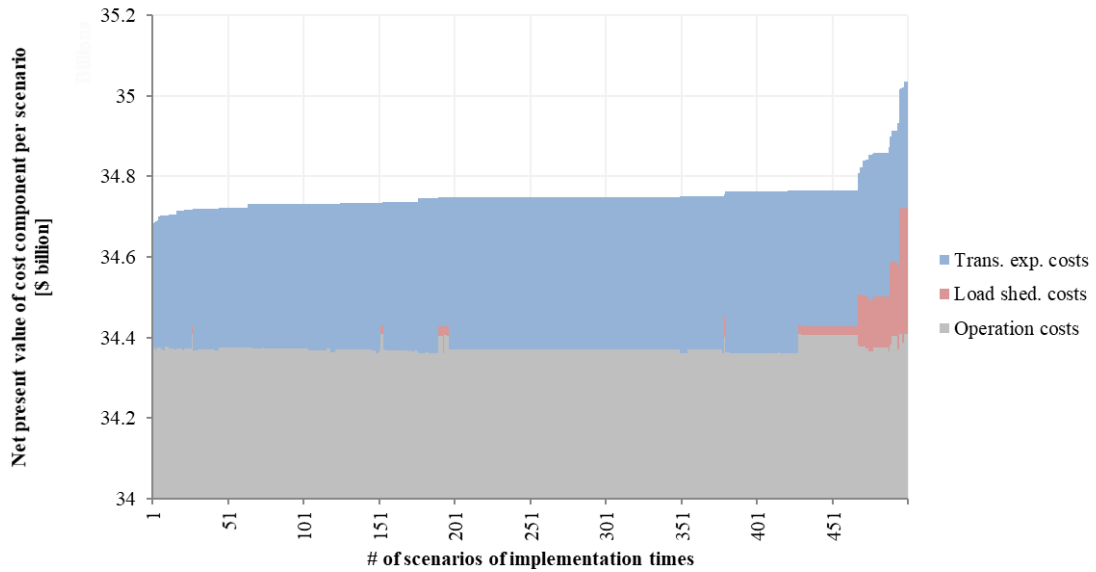

Figure 3.4: Case study results: net present value of cost components (stacked bars), for $|S_d| = 500$

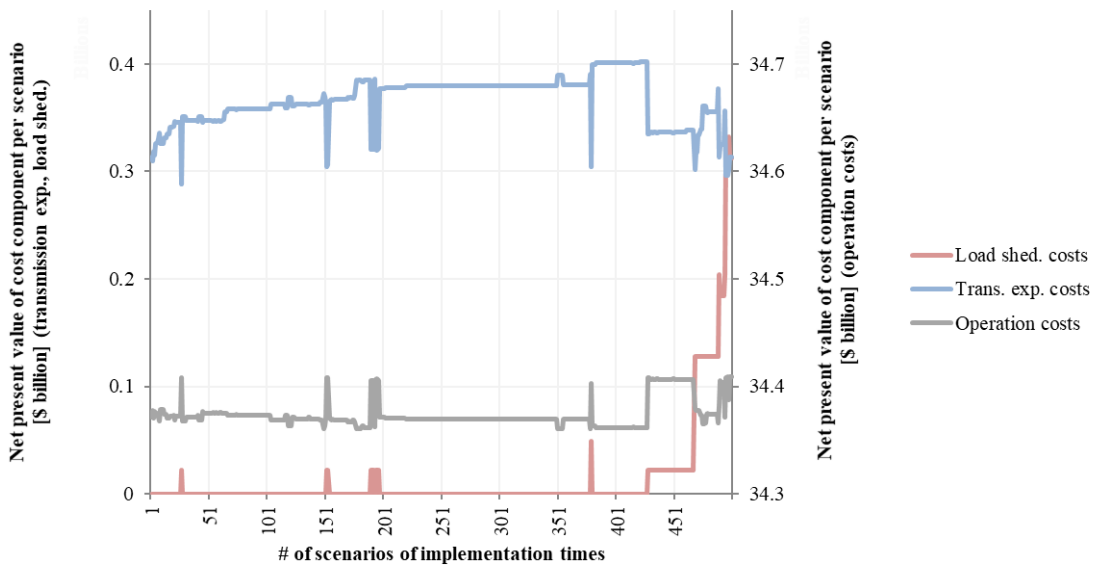

Figure 3.5: Case study results: net present value of cost components (lines, not stacked) - transmission expansion and load shedding costs (primary axis); operation costs (secondary axis), for $|S_d| = 500$.

Again, it is important to emphasize that a single set of decisions (regarding the implementation start dates) applies to all scenarios. Thus, if there were no uncertainties in implementation times, the transmission expansion costs would be equal over all

scenarios of the horizontal axis. However, due to uncertainties in implementation times, the actual costs vary significantly. As expected, in many of the scenarios the implementation times for several facilities considerably exceeded the most probable value (the mode) of the associated distributions. This reduces the cost component referring to the present value of the “annuities” that remunerate the facilities (since the facilities enter commercial operation at a later period due to delays) but increase the other cost components (operation costs and load shedding costs).

Next, we compare two specific scenarios of implementation times. This comparison aims at offering the reader further insight on the causes for the variation of costs in each period of the planning horizon. The scenarios tagged as 251 and 379 in the previous figures are compared in Figure 3.6.

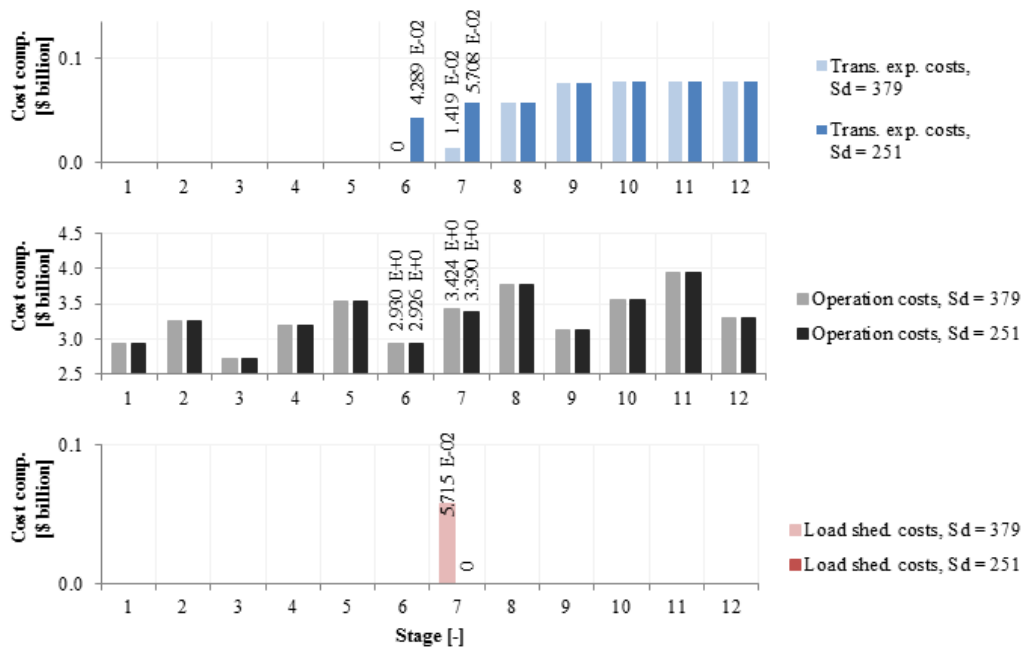

Figure 3.6: Case study results: difference in cost components for scenario 379 and scenario 251³³.

³³ The reader will notice that, since the values are given in billions of monetary units (for this example, the units implicitly represent US Dollars), values expressed in decimal cases represent tenths or hundreds of millions of monetary units. For instance, the value 1.419 E-02 \$ billion corresponds to 14.19 \$ million.

The main reason for the differences observed for scenarios 379 and 251 are the following:

- In scenario 379, the implementation time of candidate 22 is of 6 periods – i.e., the implementation starts at period 2 as indicated in Table 3.5, but only finishes at period 8. This contrast with what happens in scenario 251, where the implementation time equals 4 periods, and the circuit is already operating at period 6.
- In scenario 379, the implementation time of candidate 23 is of 7 periods, meaning that the implementation starts at period 1 but the circuit is only operational at period 8. In scenario 251, on the other hand, the implementation time is of 5 periods only and the circuit is already operating at period 6.
- The impact on the costs of system operation (generation redispatch, due to congestion) and on load shedding costs are shown in the graphic. The impacts are more significant in period 7 than in period 6 because, even though the facilities are “delayed” in both of these periods, the system load is significantly higher in period 7 than in period 6.

Also, the reader should notice that high computational burden to solve the problem, and the exponential variation of the solution time as the number of implementation time scenarios increases.

3.6 Conclusions

The results of the case study allow extracting important findings regarding the task of expansion planning with explicit consideration of uncertainties in implementation times and the methodology and mathematical formulation proposed in this document.

The first finding that can be extracted from Table 3.5 is that the implementation start dates defined by the planner in the situation where no uncertainties in

implementation times are considered, and each facility is assumed to be implemented within a time span corresponding to the most probable value of the probability distributions, differ significantly from those of the cases where this uncertainty is explicitly taken into account.

As mentioned in section 3.5.1, probability distributions of implementation times with a “mild” uncertainty were assumed for this case study. The reason to assume probability distributions with such characteristics is to show, with help of the numerical results of Table 3.5, that even in this case:

- (i) There are changes in the implementation start dates of the facilities, notably advancements with respect to the case where no uncertainty in implementation times would be considered.
- (ii) These advancements can be significant. In fact, for candidate 24, the advancement is of two 4-month periods, or 8 months. However, the advancements do not always correspond to the difference between the maximum possible value of the probability distribution and its mode – in fact, if the case with the largest sample size is taken as the reference, this is only verified for candidate 24 (and not for the other candidates). This illustrates that the optimal strategy for the planner does *not* necessarily include considering the mode (or the average value rounded to the closest integer) of the probability distribution of implementation times while determining the implementation start date. But the optimal strategy does not necessarily include being extremely conservative and considering the extreme value of the probability distribution for every circuit either.
- (iii) Also, notice that, even though candidates 24 and 25 have exactly the same distribution of implementation times, the implementation start date of candidate 24 is advanced by 2 periods in the situation where uncertainties are taken into account in comparison to the situation

where the mode of the probability distribution is used³⁴, whereas the implementation start date of candidate 25 is advanced by only 1 period under the same conditions³⁵. This shows that the advancements of the implementation start dates depend not only on the probability of implementation times that are inherent to the facilities, but also to their impacts on the operation of the power system.

A second relevant finding that can be extracted from Table 3.5 is that, even for 400 implementation time scenarios, the decisions and the value of the objective function bears important differences with respect to that obtained for 200 scenarios. Sample variance can thus be an important issue in this problem, and increasing the size of the sample can significantly increase computational burden (as shown by the solution times in Table 3.5). Though increasing the computational burden is not as critical in an expansion planning application as, say, in a system operation application, the issue merits attention.

Possible future extensions of the work are presented in chapter 5, section 5.2.2.

³⁴ More precisely, the implementation start date of candidate 24 changes: (i) from stage 6 in the situation where the mode of the probability distribution is considered; (ii) to stage 4 where a sample of implementation time scenarios of size $|S_d|=500$ is considered.

³⁵ More precisely, the implementation start date of candidate 25 changes: (i) from stage 3 in the situation where the mode of the probability distribution is considered; (ii) to stage 2 where a sample of implementation time scenarios of size $|S_d|=500$ is considered.

4 MANAGING UNCERTAINTIES IN IMPLEMENTATION TIMES OF COMPETITIVELY-PROCURED TRANSMISSION VIA OPTIMAL DESIGN OF RISK-SHARING AND WINNER SELECTION FUNCTIONS

This chapter deals with the optimal design of winner selection and risk-sharing mechanisms in competitive bidding process to award transmission concessions, with the goal of managing information asymmetries and risks associated with uncertainties in implementation times of transmission facilities. The focus is on developing and applying a methodology for this, and in drawing practical conclusions regarding the use of such mechanisms. While the mathematical elaboration of this approach may prevent its use in practice by some regulators, this chapter aims at drawing general qualitative conclusions that may be of help for regulators of all jurisdictions that face the issue of uncertainties in implementation dates of facilities and that used competitive bidding to select transmission agents.

The chapter is organized as follows:

- Section 4.1 deepens the motivation presented in the introductory chapter of this document and presents the objectives of this chapter;
- Section 4.2 contains a review of the technical literature and presents the novelties of the work;
- Section 4.3 characterizes the problem at hand, introducing concepts relevant for understanding the proposed mathematical formulation;
- Section 4.4 presents the proposed mathematical formulation to solve the problem at hand;
- Section 4.5 presents case studies and discusses their results;
- Section 4.6 contains the main conclusions of the work;

Possible future extensions of the work are presented in section 5.3.2 (chapter 5).

Before proceeding to next section, it is worth highlighting the relationship between the proposals of this chapter and the methodology of transmission expansion planning under consideration of implementation uncertainties presented in the previous chapter. It is important to explicitly consider uncertainties in implementation times at the planning stage and to determine the optimal schedule of transmission capacity additions in the plan. However, when the expansion process goes from the planning stage to the implementation stage, there may be chances of reducing the impacts of uncertainties in implementation times, and hence delays, on systemic costs by optimally selecting agent that will implement transmission facilities (and dealing with the problem of adverse selection) and by providing incentives for him to make an optimal level of efforts to implement the facilities once a concession contract is awarded to him (dealing with the problem of moral hazard). Thus, while some level of protection against uncertainties in transmission implementation times may be achieved by a careful *planning* process, using the approach presented in the previous chapter, the *implementation* stage can benefit from a careful design of winner-selection and incentives/risk-sharing mechanisms within competitive bidding processes. The proposals presented in the current chapter aims at fulfilling this second objective, related to the implementation stage.

The nomenclature used in the mathematical formulation of this chapter should be taken independently of the nomenclature used in the other chapters of this document.

4.1 Motivation and objectives

Uncertainties in transmission implementation times have increased recently, as have the frequency and severity of transmission implementation delays. This was seen in Brazil, Chile, Colombia [28], Peru [19], and even the US [20]. Such uncertainties have increased also where competitive bidding is used to select agents to which concession contracts (or similar authorizations) to implement/operate transmission

facilities are awarded, as in the countries mentioned as examples, or jurisdictions therein.

The absence of planned transmission facilities imposes costs to power systems. Upon detecting a delay, an expansion planner acts to mitigate these costs. Spotting a delay in the commercial operations date (COD) of substations in Bogotá, the Colombian planner mitigated congestion costs, installing equipment [28] in existing substations. There are also conceptually similar examples in Brazil, where delays in the COD of a transmission line that would supply a state capital in the northern part of the country, which is currently an isolated system, required continued operations of thermal generation running on fossil fuels [51].

Usually, the costs of mitigating the impacts of the absence of a planned transmission facility are lower if the actual COD is learned with antecedence – e.g., this allows sourcing fuels for local generation at lower prices. But planning mitigating actions under uncertainties in implementation times is challenging.

Knowing this, entities using competitive bidding to award transmission concession contracts embed contracting processes with mechanisms to deal with uncertainties in implementation times. Some jurisdictions, as Brazil & Chile [52]-[53], subject the transmission company (transco) to penalties due to delays with respect to a contractual *target COD*, or positive incentives when CODs are advanced. Others, as Ontario [54] and California [55], also include a feasibility evaluation of the asset implementation schedule among winner-selection criteria in the competition.

The penalties due to delays and positive incentives in case of advancements of the COD represent a risk-sharing mechanism: transcos are incentivized to comply with contractual CODs by bearing a parcel of systemic costs of delays, with penalties used to partially compensate (transfer) these costs, and by capturing part of the avoided costs when the actual COD is advanced.

Within a competitive bidding process, penalties and positive incentives also help revealing the possibilities of the transcos of committing to contractual target CODs: a transco perceiving a high probability of delays and penalties will incorporate risk

premiums in its monetary bid (revenues required to implement/operate facilities), making it less attractive.

Direct evaluations of implementation schedules provide the entity in charge of the competitive process with information on the possibilities of transcos reliably committing to contractual CODs. They can thus be seen as a screening mechanism targeted at reducing information asymmetries between the transco and the regulator.

The presence of asymmetric information (more specifically in this case, private information of the transmission company regarding its ability to commit to a contractual COD and the costs it incurs to ensure that the facilities commence operations at that contractual target) *before* the signature of the contract³⁶ leads to the need of the regulator dealing with the *adverse selection problem* [56], where the party with private information (in this case, the transco) selectively seeks to take part in contracts in which it benefits the most, at the expense of the other party. For instance, a transco that is highly efficient in implementing facilities, and perceives low costs of taking measures to cope with whichever implementation challenges that it may find during the construction of facilities, may seek to withhold this information from the regulator and “convince” him that it is in fact less inefficient, such that the regulator will share less risks with the transco as part of the contract (in order to reduce the risk premium that the transco would factor into its bid to what the “deceived” regulator would perceive to be an optimal level).

On the other hand, the fact that the regulator cannot fully observe and verify the level of efforts the transmission company selected as a result of the auction will make to cope with whichever implementation challenges materialize *after* the agent has signed the contract and has begun the implementation of the facilities, (i.e., the fact that there is *hidden action*) leads to the need of the regulator dealing with *moral hazard problem* [56]. For instance, if the regulator does not subject the transco to sufficient incentives, the agent may simply opt to not make any efforts (and thus not incur any costs of those

³⁶ The reader will recall that the contract will only be signed after the competitive process.

efforts) if it faces any challenges found after the implementation begins, which would increase the implementation time of the facilities, imposing costs to the power system.

The optimal design of winner selection and risk-sharing mechanisms in the context of competitive biddings to select transmission agents can be seen as a way of dealing simultaneously dealing with the adverse selection problem³⁷ and with the moral hazard problem³⁸, in a context where the transmission agents and the planners/regulators are risk-averse.

The main objectives of this chapter are to: (a) formally analyze the potential of risk-sharing and winner-selection mechanisms to manage information asymmetries and risks associated with uncertainties in implementation times of transmission facilities, when competitive bidding is used to select transcos; and (b) to extract general recommendations for the optimal design and use of these mechanisms. We also investigate the potential benefits of letting transcos choose the target COD to which they commit in the concession contract, and use this commitment as a variable in the winner-selection/risk-sharing functions. The possibility of choosing the target COD allows the transco to select among *higher-* and *lower-powered* incentives regarding delays.

For that, we formulate and employ a MILP (mixed-integer linear programming) model to optimally design risk-sharing/winner-selection functions, applying principal-agent theory concepts to the selection of transcos via competition, when implementation time uncertainties are an issue. The objective of the principal is to determine the

³⁷ The adverse selection problem is relevant in this context because the regulator is not aware of the efficiency of the transcos competing in the auction regarding their possibilities of committing to contractual CODs and their efficiency in coping with implementation challenges encountered *ex post*, while each transco knows their own efficiency, even if they are uncertain regarding which challenges will effectively materialize during the implementation.

³⁸ The moral hazard problem is relevant in this context because the problem is characterized by hidden action, since the transmission companies selected as a result of the auction could, if they are not subject to sufficient incentives, opt not to make sufficient efforts to cope with whichever implementation challenges that appear during the implementation of the facilities, and the regulator will not have full possibilities of directly observing whether these *ex post* efforts correspond to the full possibilities of the transco or not.

parameters of the risk-sharing/winner-selection functions to minimize all costs involved in procuring/implementing transmission, including risk premiums factored in the competitors' bids and systemic costs/benefits of delays/advancements, while: (i) modelling transcos' responses to risk-sharing/winner-selection functions; (ii) accounting for costs of actions to mitigate the absence of planned transmission facilities, which are lower in case actual CODs are learned with antecedence and higher for unforeseen delays; (iii) modelling uncertainty in implementation times and in performances of different types of transcos that may take part in bidding; (iv) modeling risk-aversion of transcos and regulators.

4.2 Literature review and novelties of the approach

The novelties of the chapter relate to applying principal-agent theoretic concepts [57] to deal with uncertainties in transmission implementation times when contracts to implement and operate facilities are awarded via competitive bidding. To the best of our knowledge, this application has not been addressed in the literature. Principal-agent theory concepts have been applied to electricity transmission & distribution before, but mainly for the regulation of agents under classical models of incumbents with territorial franchises, and almost always focusing on uncertainties on the cost function of the agent (see [58]-[62] and references therein). In [63], a principal-agent approach is used to design incentives applicable to transmission expansion via competitive bidding, but the focus is on dealing with uncertainties on cost-overruns due to negotiations of agents and landowners regarding rights-of-way (and the performance of the transco in this task).

Our focus on incentives targeted at implementation times of transmission leads to the extension of classical agent-principal approaches to incorporate the following: (i) the systemic costs due to the absence of a planned transmission facility change with the antecedence with which delays are detected; (ii) the time dimension of the problem is

fully represented, adding to the complexity of the problem and impacting the formulation – a MILP framework is used to enable computational tractability.

4.3 Problem characterization

We begin this section by presenting basic aspects of the problem setup that aid the understanding of the formulation of section 4.4.

The problem is formulated from the standpoint of a regulator/planner (principal) that designs incentives to select a transco (agent) to implement and operate facilities. Figure 4.1 shows parameters and variables used in this text:

- the months t of the horizon;
- the *ex-ante* avoided costs (b_t);
- the *natural probability distribution of the COD* of the facilities perceived by transco j (\tilde{V}_j);
- the *advancement of \tilde{V} due to efforts* of transco j ($\tilde{\Delta}_j$);
- the *target COD* chosen by transco j as a contract commitment (Ψ_j);
- the *maximum month that can be declared as Ψ_j by transcos* (D , with $\Psi_j \leq D$ always holding);
- the *final month of the contract* (T).

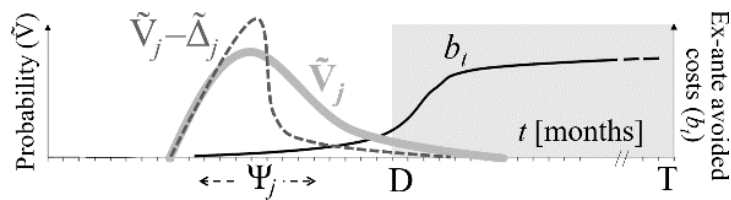

Figure 4.1. Illustration of variables relevant for describing the problem setup

The set $j \in J$ represents the classes of transcos competing in the bidding process. Classes represent typologies of agents with similar project implementation efficiency, cost functions & risk aversion.

We adopt a simplifying assumption that competition among transcos of a class is sufficiently high so that the best bid from each class strictly recovers costs (capital remuneration included) at a given risk metric. This allows us to focus on the managing of uncertainties in implementation times via risk-sharing/winner-selection, without having to extensively model the competition process *per se*, or any strategic behavior within it. Despite this assumption, the situation at hand is an instance of the principal-agent problem, due to the regulator needing to design incentives that lead to the optimal choice among classes of transcos with different project implementation performances and risk-aversions, and to incentivize the chosen transco to make sufficient efforts to avoid delays after the contract begins. Having stated this assumption, we use the terms *transco* and *class of transcos* interchangeably in the remainder of the text.

Other symbols are defined as they become necessary. Unless otherwise stated, parameters are denoted by Latin letters, and decision variables by Greek letters

4.3.1 Systemic costs in the absence of planned transmission

The absence of a planned facility increases systemic costs (due to congestion, losses, etc.). As per section 4.1, the level of costs of the absence of the facility depends on the antecedence with which the planner realizes that the COD will be delayed.

In Figure 4.1, the *ex-ante avoided costs* b_t represent the planner's estimate, at the time of the competitive bidding process to select the transco that will implement and operate the facility, of the costs that will incur if the facility is not operational in a month t of the analysis horizon. These costs can vary in time. Transcos, including the competition winner, choose the contractual *target COD* Ψ_j to which they commit, and this information is available *ex ante* (with enough antecedence to allow the planning of mitigating actions, since it is known as a result of the auction) to the principal. The systemic costs avoided in each t after Ψ_j in which the facility is effectively operational are b_t .

Since the principal planned mitigating actions for the absence of a facility considering that it would likely commence operations at $t = \Psi_j$, the systemic costs of the absence of the facility in every $t \geq \Psi_j$ (i.e., in the case of unforeseen delays) will be higher than or equal to b_t . The *ex-post costs due to delays* are thus defined by $a_t \cdot b_t$, with $a_t \geq 1$ for all months t ($\forall t$).

Conversely, if the facility commences operations before the target COD Ψ_j to which the transco committed, the systemic costs avoided will tend to be lower than b_t , since the principal would already have taken actions to mitigate the impacts of the absence of facilities until Ψ_j . The *ex-post avoided costs due to unplanned advances of the COD* are thus $e_t \cdot b_t$, with $e_t \leq 1 \forall t$.

The first case study of section 4.5 exemplifies why $e_t \cdot b_t \leq b_t \leq a_t \cdot b_t$. In this chapter, we adopt the simplifying assumption that $e_t = e$ and $a_t = a \forall t$.

4.3.2 Shape of winner selection and risk-sharing functions

The principal aims at determining optimal risk-sharing and winner-selection functions to minimize systemic costs involved in contracting and implementing transmission. Under the assumption that competition is high enough so that the best bid from each class of transcos strictly recovers costs at a given risk metric, the *profit at risk* of the transco is zero and the principal's objective to minimize systemic costs is a proxy of the objective of maximizing the total welfare of the contractual relationship.

We define pre-determined shapes of risk-sharing/winner-selection functions, and the principal optimizes the parameters of these functions. He selects the winner of the bidding process with basis on: (i) the *revenue required by* the transco in each month of the contract in which the facility is operating, a monetary value ρ_j fixed in real terms; and (ii) the *target COD* Ψ_j declared and contractually committed to by the transco. The shape of the winner selection function, $F[\rho_j, \Psi_j | \sigma]$, is:

$F[\rho_j, \Psi_j \sigma] = \sum_{t=\Psi_j}^T \rho_j \cdot h^t - \sigma \cdot \sum_{t=\Psi_j}^{D-1} b_t \cdot h^t$	(49)
--	--------

$w = j^* = \arg \min_{j \in J} \{ F[\rho_j, \Psi_j \sigma] \}$	(50)
--	--------

where:

- $w = j^*$ Winning transco selected by the principal;
- h Principal's factor for time discounting of money;
- σ Parameter of function F optimized by the principal.

By eq. (49), the winner of the competitive process will be the transco whose declaration of (ρ_j, Ψ_j) results in the minimal value of the difference between (i) the present value (PV) of payments to the transco, and (ii) the PV of avoided costs due to the transco committing to a Ψ_j sooner than D , escalated by σ . The principal adjusts σ before the auction, using the model of section 4.4.

This winner-selection function captures the dynamics of system costs and costs of contracting the transco in a simplified way, without accounting for uncertainties in the actual COD of the facilities (i.e., implicitly assuming that the actual COD will match Ψ_j). This is consistent with regulatory practices of not specifying overly complex winner-selection functions, to make the selection process as simple and transparent as possible. Yet, the risk-sharing mechanisms will transfer part of the risks of delays to the transco and optimally align the interests of the principal and the agent, and the transco itself will be responsible for adjusting the declared (ρ_j, Ψ_j) to account for these risks – a response that will ultimately affect the winner selection as well.

Risk-sharing is made by transferring to the transco: (i) a parcel ζ/a of the *ex-post costs due to delays* incurred in $t \geq \Psi_j$ in which the facility is not yet operational, by means of penalties; (ii) a parcel β of the *ex-ante avoided costs* that are effectively avoided in months $\Psi_j \leq t < D$ in which the facility is operational, by means of a positive incentive; (iii) a parcel ξ/e of *ex-post avoided costs due to unplanned advances of the COD* in $t < \Psi_j$ in which the facility is effectively operational, via a positive incentive. Table 4.1 below presents the exact shapes of these risk-sharing sub-functions (ζ, β and ξ are parameters optimized by the principal).

Table 4.1. Shape of Risk-Sharing Sub-Functions (Before Taxes)

Shape of risk-sharing sub-function (as seen by transco, before effects of taxes)	Implicit limit to parameter	Seen by transco as a	Function aims at sharing risks (possibilities of losses or gains) due to
$-\sum_{t=\Psi_j}^{(V_{j,s}-\Delta_{j,s}-1)} \zeta \cdot b_t \cdot r_j^t$	$\zeta \leq a$	Loss	<i>ex-post costs due to delays</i>
$\sum_{t=\max(\Psi_j, V_{j,s}-\Delta_{j,s})}^{D-1} \beta \cdot b_t \cdot r_j^t$	$\beta \leq 1$	Gain	<i>ex-ante avoided costs</i>
$\sum_{t=V_{s,j}-\Delta_{j,s}}^{(\Psi_j-1)} \xi \cdot b_t \cdot r_j^t$	$\xi \leq e$	Gain	<i>ex-post avoided costs due to unplanned advances of COD</i>

In Table 4.1, r_j is the time discounting factor modelling the intertemporal preferences and capital costs of transco j ³⁹. The stochastic parameter $V_{j,s}$ is sampled from \tilde{V}_j , and $V_{j,s}-\Delta_{j,s}$ is the actual COD of the facility in scenario s . The decision variable $\Delta_{j,s}$ is explained in section 4.3.4. The limits of the summations implement the risk-sharing mechanisms of the previous paragraph in an exact fashion, exposing transcos to part of systemic costs (benefits) when the actual COD of the facilities is delayed (advanced).

The transco responds by: (i) forming its bid, by choosing (ρ_j, Ψ_j) to manage risks and ensure that revenues, under risk criteria, at least recover its costs; (ii) making *ex post* efforts, if it wins the competition, to maximize profits for whichever scenario s materializes. The extent to which systemic risks are transferred to the transco depends on the principal's choices of ζ , β and ξ .

In practice, there are hurdles in using the exact shapes of the risk-sharing sub-functions of Table 4.1. Regulators may hesitate to define penalties and positive incentives with the complexity resulting from a dependence on b_t , as this is a quantity that can change in time. But the principal can define a value B somehow representative of the values of b_t during a relevant parcel of the horizon (for an example, see case study A in section 4.5.1) and employ the simplified definitions of risk-sharing functions

³⁹ The parameter r_j can be understood as being the weighted average cost of capital (WACC) of the transco, meaning that it captures its capital costs (equity costs).

of Table 4.2. In this case, despite penalties and positive incentives not being strictly proportional to b_t , risk-sharing still occurs, due to the values of the sub-functions being dependent on $V_{j,s}-\Delta_{j,s}$ and Ψ_j .

Table 4.2. Simplified Risk-Sharing Sub-Functions (Before Taxes)

Shape of simplified risk-sharing sub-function (as seen by transco, before effects of taxes)	Implicit limit to parameter	Seen by transco as a	Function aims at sharing risks (possibilities of losses or gains) due to
$-\sum_{t=\Psi_j}^{(V_{j,s}-\Delta_{j,s}-1)} \zeta \cdot B \cdot r_j^t$	$\zeta \leq a$	Loss	<i>ex-post costs due to delays</i>
$\sum_{t=\max(\Psi_j, V_{j,s}-\Delta_{j,s})}^{D-1} \beta \cdot B \cdot r_j^t$	$\beta \leq 1$	Gain	<i>ex-ante avoided costs</i>
$\sum_{t=V_{s,j}-\Delta_{j,s}}^{(\Psi_j-1)} \xi \cdot B \cdot r_j^t$	$\xi \leq e$	Gain	<i>ex-post avoided costs due to unplanned advances of COD</i>

The principal often finds practical limits to levels of positive incentives – e.g., due to public opinion opposing to significant levels of avoided costs being transferred to transcos, even if this is the optimal solution. In these cases, the principal can consider explicit upper limits to β and ζ . Lower limits to ξ are also found in some cases; e.g. due to legal concerns of ensuring a minimum remuneration after facilities are operational. Since transcos only capture the contractual ρ after the actual COD, as explained in section 4.3.3, ξ must exceed zero to comply with such a legal requirement.

4.3.3 Competitive bidding & definition of transmission contract

The bids presented by the transcos in the competitive process include two values: the *revenue requirement* ρ_j and the commitment to *target COD* Ψ_j . Revenues ρ_j are only captured after the target COD to which the transco commits or after the actual COD of facilities, whichever comes last. This is also an incentive to transcos – a risk-sharing device inherent to the contract, independent of the choice of ζ , β , ξ (yet, the choice of parameters can strengthen or weaken overall incentives).

Classical principal-agent problem setups focus on the situation where agents can choose from a menu of contracts including various combinations of a remuneration fixed *ex ante* and a reimbursement that closely matches the actual incurred costs [57]. Our focus on managing of implementation delays leads to another setup: we assume exclusively a *fixed level of remuneration* (ρ_j), but let the transco choose from an interval of target CODs, $\Psi_j \in [1, D]$. The choice of Ψ_j determines whether the incentive scheme is a *high-* or a *low-powered* one: for most values of (ζ, β, ξ) , transcos can opt for stronger incentives (with higher exposure to delay penalties but with the possibility of capturing higher positive gains in case of advancements) by committing to a sooner Ψ_j . The principal can tailor the menu of contracts available to transcos by adjusting the parameters ζ, β and ξ , and he will do so (and choose the value of σ) optimally.

The principal fully defines the (long-term) contract before the competition, and cannot negotiate its terms afterwards.

4.3.4 Uncertainties seen by transcos and principal, information asymmetries and robust-decision making of the principal

Transcos face uncertainties in feasible implementation times of facilities, and so need to consider various scenarios $s \in S$ ($V_{j,s}$ sampled from \tilde{V}_j) while bidding and reacting to the risk-sharing/ winner-selection functions designed by the principal. But \tilde{V}_j is only the *natural* probability distribution of the actual COD – a distribution dictated by unforeseen challenges, like geological hurdles for laying tower foundations. The transco *estimates* \tilde{V}_j before the bidding process, but is only able to determine *exactly* which $V_{j,s}$ materializes after it made its bid and started the implementation works. Uncertainties thus only materialize after the bidding process – e.g., due to foundation excavations (and the finding of geological hurdles) only happening at that point.

But the transcos can *react* to the challenges detected *ex post*, e.g. by using advanced engineering techniques or going around difficult sites by altering line routes. If transco j encounters a high-valued $V_{j,s}$, it may advance the actual COD by $\Delta_{j,s}$ months

in scenario s , by making efforts resulting in $V_{j,s} - \Delta_{j,s}$ being the actual COD of the facilities. Those efforts come at the cost of increasing capital expenditures (capex) perceived by the transco – we assume that the capex increases linearly by $\varepsilon_j \Delta_{j,s}$, where ε_j is the *efficiency parameter* of j . The transco only decides on $\Delta_{j,s}$ after the bidding ends (due to the *ex post* decision, this is a stochastic decision variable, denoted by $\tilde{\Delta}_j$), and will only opt to make efforts and incur costs if incentives are sufficiently high. The principal considers this while optimizing ζ , β , ξ and σ .

But the principal faces a complex problem, since he cannot be sure of the distribution \tilde{V}_j , the efficiency parameter ε_j , or other parameters of the cost function (reference capex, capital costs, O&M costs) of the classes of transcos that participate in the bidding process. To model these uncertainties, he:

- (a) Defines a comprehensive set of classes of transcos, $j \in J$, that may participate in the auction, considering all reasonable combinations of descriptive parameters of the transcos (\tilde{V}_j , ε_j and others) that make economic sense for his jurisdiction.
- (b) Defines a set of *bidder participation scenarios*, $m \in M$, representing subsets of J , J_m , that may jointly participate in the bidding process. For instance, assume: (i) there are three transco classes, $J = \{1,2,3\}$; and (ii) the principal believes that only two bidder participation scenarios are relevant for his analyses, that in which all three classes participate in the bidding, and that in which only $j=1$ and $j=3$ take part in it. The principal would then define $M = \{1,2\}$, $J_{m=1} = \{1,2,3\}$, and $J_{m=2} = \{1, 3\}$.
- (c) Uses a *minimax* approach [64]-[65] to determine ζ , β , ξ and σ : he determines the optimal values of the parameters to minimize the highest among the systemic costs involved in contracting the agent and implementing the transmission facilities for all m . Notice that the principal takes decisions under uncertainties regarding the descriptive parameters of the transcos – which is consistent with the discussion on information asymmetries presented in section 4.1.

4.4 Mathematical formulation

This section presents the mathematical formulation of the proposed approach for the principal-agent problem at hand, in which the principal aims at optimizing the winner-selection and risk-sharing functions as a strategy for managing implementation delays of competitively-procured transmission.

The problem to be solved by the principal is schematically defined as:

$\min_{\zeta, \xi, \beta, \sigma} \{ \Gamma \}$	(51)
subject to	
$\Gamma \geq C_p[\zeta, \xi, \beta, \rho_{w(m)}, \Psi_{w(m)}, \tilde{\Delta}_{w(m)}, \tilde{V}_{w(m)}]$; $\forall m \in M$ (52)
$w(m) = j^{*,m} = \arg \min_{j \in J_m} \{ F[\rho_j, \Psi_j \sigma] \}$; $\forall m \in M$ (53)
$\{\rho_j, \Psi_j, \tilde{\Delta}_j\} = \arg \min_{\rho_j, \Psi_j, \tilde{\Delta}_j} \{ F[\rho_j, \Psi_j \sigma] \text{ subject to } K_j[\rho_j, \Psi_j, \tilde{\Delta}_j \zeta, \xi, \beta, \tilde{V}_j] \leq 0 \}$; $\forall j \in J$ (54)

where:

- C_p Function that denotes a risk metric of the systemic costs seen by the principal, [\$];
- $w(m)$ Winner of the competitive bidding process under bidder participation scenario m ;
- K_j Function that denotes the risk metric of the losses resulting from the implementation and operation of the facilities seen by transco j , [\$];
- Γ Auxiliary continuous decision variable to obtain the highest among the values of C_p across all bidder participation scenarios.

Via obj. function (51), the principal defines the parameters of the risk-sharing and winner-selection functions (ζ , β , ξ , and σ) to minimize the highest among the systemic costs involved in contracting and implementing the facilities across all m .

Constraint (52) determines these costs for all $m \in M$. Notice that C_p depends not only on the risk-sharing parameters ζ , β and ξ , but also on the bid (ρ_w, Ψ_w) of the winning transco w , on its ex-post decisions $\tilde{\Delta}_w$, and on its natural distribution of CODs \tilde{V}_w . The function C_p will be thoroughly defined in section 4.4.2.

Constraint (53) models the winner-selection process. For each m , the principal selects the transco $w(m) = j^* \in J_m$ whose bid minimizes function F , which in turn depends on σ . The model of the winner-selection process is discussed in details in section 4.4.2.

Constraint (54) states that the principal considers how transcos respond to his decisions on risk-sharing and winner-selection functions, by assuming that each transco behaves as follows: (a) it defines its bid to minimize the winner-selection metric, thus maximizing its chances to win the bidding process⁴⁰; (b) while ensuring that the risk metric of the monetary losses it incurs as a result of the contract is strictly non-positive (hence, profits are non-negative)⁴¹. Notice that K_j depends on the parameters ζ , ξ , and β defined by the principal. Details on the behavior of the transco are provided in section 4.4.1.

⁴⁰ This is functionally similar to the *incentive compatibility constraint* of classical references of principal-agent theory [57]: the agent will select the contract (in our case, by determining the value of Ψ_w in its bid and thus opting for a higher- or a lower-powered contract) to optimize his own economic position. Under the assumption that competition is high enough so that the best bid from each class of transcos strictly recovers costs (including capital remuneration) at a given risk metric, the profit at risk of the transco is zero. Thus, the only way that the transco can maximize its utility at risk is to maximize the probability that it is the auction winner (and therefore captures the capital remuneration), which it does by minimizing the winner-selection metric.

⁴¹ This is functionally similar to the *individually rationality constraint* of classical references of principal-agent theory [57]: the agent will only take part in the transaction if the utility it captures at least equal its reservation utility, which is set to zero in our case since the weighted average cost of capital used to determine the net present value captures the requisites on equity remuneration (which, in their turn, are determined by the opportunity costs the agent perceives).

4.4.1 Detailing the problem of the transco

To detail the transco behavior model succinctly presented in eq. (54), the first step is to present the expression for calculating the PV of the losses perceived by the transco in scenario s , $\mu_{j,s}$:

$\begin{aligned} \mu_{j,s} = & N_j \cdot (1 + \varepsilon_j \cdot \Delta_{j,s}) \\ & + \sum_{t=V_{j,s}-\Delta_{j,s}}^T c_j \cdot y \cdot r_j^t \\ & - \sum_{t=\max\{\Psi_j, V_{j,s}-\Delta_{j,s}\}}^T \rho_j \cdot d \cdot y \cdot r_j^t \\ & + \sum_{t=\Psi_j}^{V_{j,s}-\Delta_{j,s}-1} \zeta \cdot B \cdot y \cdot r_j^t \\ & - \sum_{t=\max\{\Psi_j, V_{j,s}-\Delta_{j,s}\}}^{D-1} \beta \cdot B \cdot y \cdot r_j^t \\ & - \sum_{t=V_{j,s}-\Delta_{j,s}}^{\Psi_j-1} \xi \cdot B \cdot y \cdot r_j^t \end{aligned}$	$; \forall s \in S$	(55)
--	---------------------	--------

where:

- N_j PV of the reference capex (before increases due to efforts to advance the COD) of j , [\$];
- c_j Value of operational expenses (opex) incurred in each month t in which the facilities are operating [\$];
- x Income tax rate;
- y Factor that equals $(1-x)$;
- d Factor for discounting gross revenues due to applicable charges.

In eq. (55), positive and negative terms represent the PV of costs and revenues, respectively. The terms in the first two lines of the right-hand-side of (55) are the capex and the opex seen by the transco (opex adjusted by taxes). The third term represents the revenues ρ_j captured by the transco (after taxes and charges). The last three lines model impacts of the risk-sharing functions of Table 4.2 on the transco's cash flow, after

adjusting for taxes. Clearly, $\mu_{j,s}$ depends on the parameters to which transco j commits in the bidding process, (ρ_j, Ψ_j) , and on the actual COD in scenario s .

We proceed to the format of function K_j . The transco's risk-aversion is modelled by assuming the risk metric it chooses to minimize is the conditional value at risk (CVaR) [66] of the PV of losses for the risk parameter p_j (i.e., the expected losses across the $(1-p_j) \cdot |S|$ worst scenarios). Taking advantage of $\mu_{j,s}$ being non-decreasing over the only stochastic parameter in the transco's problem (\tilde{V}_j) for all relevant values of ζ , β and ξ , we use this simple formulation of the CVaR function, whose value is denoted by κ_j :

$\kappa_j = \{1/[(1 - p_j) \cdot S]\} \cdot \sum_{s \in \hat{S}_j} \mu_{j,s}$	(56)
---	--------

where:

S Entire sample of scenarios s ;

\hat{S}_j Subset of S with the highest $(1-p_j) \cdot |S|$ values of $V_{j,s}$ (defined offline).

Having defined κ_j , we can fully determine the optimization problem to be solved by each transco j and that is represented schematically by the term within the curly brackets of eq. (54):

$\min_{\rho_j, \Psi_j, \{\Delta_{j,s} \forall s \in S\}} \{\sum_{t=\Psi_j}^T \rho_j \cdot h^t - \sigma \cdot \sum_{t=\Psi_j}^{D-1} B \cdot h^t\}$	(57)
---	--------

subject to

constraints (55) and (56)	
$\kappa_j \leq 0$	(58)
$\Psi_j \leq D$	(59)
$\Delta_{j,s} \leq \Delta_{max} \quad ; \forall s \in S$	(60)
$\Psi_j \in \mathbb{Z}$	(61)

$\Delta_{j,s} \in \mathbb{Z}$	$; \forall s \in \mathcal{S}$	(62)
-------------------------------	-------------------------------	--------

where Δ_{max} is an upper limit to the number of months by which the transco can advance the actual COD of the facilities, defined by its technological possibilities (e.g., resource limitations).

Objective function (57) states that the transco seeks to minimize its winner-selection metric.

Constraint (55) defines the PV of the losses incurred by the transco in each scenario s . Constraint (56) determines the CVaR of these losses; and constraint (58) ensures that this CVaR is strictly non-positive. To minimize its winner-selection metric, the transco⁴² will seek to decrease the values of ρ_j and Ψ_j . This will tend to increase the CVaR of its losses, and the transco will only be able to do that until reaching a CVaR of zero.

Constraint (59) imposes the rule that the transco cannot commit to a contractual COD Ψ_j higher than D . Constraint (60) imposes the upper bound Δ_{max} on the advances of the COD. Constraint (61) and (62) state that Ψ_j and $\Delta_{j,s}$ are integer decision variables.

This formulation does not correspond to a MILP, since decision variables (Ψ_j , $\Delta_{j,s}$) appear as limits in summations. The techniques used for reformulating it as a MILP are presented below⁴³:

- (a) Introduce binary decision variables ψ_t , for all t in $[1, T]$; where $\psi_t = 1$ if $t \geq \Psi_j$ and 0 otherwise; $\psi_t \geq \psi_{t-1}$ always holds.
- (b) Introduce auxiliary binary decision variables $\delta_{z,s}$, for all z in $[1, \Delta_{max}]$ and s in \mathcal{S} ; $\delta_{z,s} \leq \delta_{z-1,s}$ always holds. Index z indicates months and relates to t via the transformation $t = V_{j,s} - z$. Variable $\delta_{z,s}$ equals 1 if, in scenario s , the transco's efforts resulted in the facility already being operational in $t = V_{j,s} - z$. The

⁴² The reader will recall that ζ , β , ξ , σ are parameters for the transco, but decision variables for the principal.

⁴³ Below, for the sake of notation conciseness, variables are not indexed by j .

expression $\Delta_s = \sum_{z \in [1, \Delta_{max}]} \delta_{z,s}$ can be used for direct substitutions in (60) and in the term referring to the capex in (55).

- (c) These auxiliary variables allow the MILP reformulations of Table 4.3, where $f(t)$ denotes a general argument of the summation, and U is a general upper bound. Notice that $D \ll T - \Delta_{max}$ always holds.

Table 4.3. MILP Reformulations of Summations with Ψ_j & $V_{j,s}$ as Limits

Original formulation	MILP reformulation of the term
$\sum_{t=\Psi_j}^U f(t)$	$\sum_{t=1}^U \psi_t \cdot f(t)$
$\sum_{t=V_{j,s}-\Delta_{j,s}}^T f(t)$	$\sum_{t=V_{j,s}}^T f(t) + \sum_{z=1}^{\Delta_{max}} \delta_{z,s} \cdot f(V_{j,s} - z)$
$\sum_{t=\max\{\Psi_j, V_{j,s}-\Delta_{j,s}\}}^T f(t)$	$\sum_{t=V_{j,s}}^T \psi_t \cdot f(t) + \sum_{z=1}^{\Delta_{max}} \delta_{z,s} \cdot \psi_{V_{j,s}-z} \cdot f(V_{j,s} - z)$
$\sum_{t=\Psi_j}^{V_{j,s}-\Delta_{j,s}-1} f(t)$	$\sum_{t=1}^{V_{j,s}-1} \psi_t \cdot f(t) - \sum_{z=1}^{\Delta_{max}} \delta_{z,s} \cdot \psi_{V_{j,s}-z} \cdot f(V_{j,s} - z)$
$\sum_{t=\max\{\Psi_j, V_{j,s}-\Delta_{j,s}\}}^{D-1} f(t)$	$\sum_{t=V_{j,s}}^{D-1} \psi_t \cdot f(t) + \sum_{z=\max\{1, V_{j,s}-D+1\}}^{\Delta_{max}} \delta_{z,s} \cdot \psi_{V_{j,s}-z} \cdot f(V_{j,s} - z)$
$\sum_{t=V_{j,s}-\Delta_{j,s}}^{\Psi_j-1} f(t)$	$\sum_{t=V_{j,s}}^{D-1} (1 - \psi_t) \cdot f(t) + \sum_{z=1}^{\Delta_{max}} \delta_{z,s} \cdot (1 - \psi_{V_{j,s}-z}) \cdot f(V_{j,s} - z)$

After using the techniques of Table 4.3, trivial reformulations of products of binary decision variables, with aid of disjunctive constraints [67], are used to get the final MILP reformulation⁴⁴.

4.4.2 Detailing the problem of the principal

The use of a MILP formulation for modeling the behavior of the transco influences the strategy for solving problem (51)-(54) as a whole, due to the complexity that would arise from treating it as a single multi-level problem with integer decisions in

⁴⁴ The final reformulation is tractable with commercial solvers. This is the main reason for preferring a MILP over the non-linear program that could be obtained by using algebraic manipulations with the equality $\sum_{t=L}^U r^t = (r^L - r^{U+1}) / (1 - r)$, for $r < 1$.

the lower-level. To avoid this complexity, the strategy chosen for solving (51)-(54) is based on discretizing the search space (the \mathbb{R}^4 space defined in the variables ζ, β, ξ and σ) of the principal's problem. Though the solutions for the discretized search space may be sub-optimal with respect to these that would be obtained if the continuous \mathbb{R}^4 space were searched, the strategy sufficed for extracting relevant conclusions, as indicated in section 4.6.

The principal discretizes the search space, defining the set $g \in G$ of points $(\zeta^g, \beta^g, \xi^g, \sigma^g)$. As per section 4.3.4, he also defines the sets J, M , and $\{J_m \forall m \in M\}$. He then uses the procedure of Figure 4.2 to solve the problem schematically described by (51)-(54).

- 1: Solve the MILP reformulation of (7)-(13) for all combinations of transcos $j \in J$ and points $g \in G$. Store the solutions of the transco problem (the responses of the transco, ρ_j^g, Ψ_j^g , and $\{\Delta_{j,s}^g \forall s \in S\}$) obtained for each combination (j, g) .
- 2: Solve equation (53), via a trivial search over the finite set J_m , to determine the winning transco $w(m)$, for each scenario $m \in M$ and each point $g \in G$.
- 3: With the results $\rho_{w(m)}^g, \Psi_{w(m)}^g, \{\Delta_{w(m),s}^g \forall s \in S\}$ at hand for all $m \in M$ and $g \in G$, solve the MILP (63)-(69) presented below to obtain the solution of the problem of the principal.

Figure 4.2. Procedure for solving the problem of the principal described in (51)-(54)

The MILP corresponding to step 3 of this procedure is:

$\min_{\{v_g \forall g \in G\}} \{ \Gamma \}$	(63)
---	--------

subject to

$\Gamma \geq \theta^m + \frac{1}{(1-p_p) \cdot S } \cdot \sum_{s \in S} \gamma_s^m$; $\forall m \in M$	(64)
--	---------------------	--------

$\gamma_s^m \geq \eta_s^m - \theta^m$; $\forall m \in M, s \in S$	(65)
---------------------------------------	------------------------------	--------

$\eta_s^m = \sum_{g \in G} v_g \cdot n_{s,g}^m$; $\forall m \in M, s \in S$	(66)
---	------------------------------	--------

$\sum_{g \in G} v_g = 1$	(67)
--------------------------	--------

$\sum_{g \in G} v_g \cdot \beta_g \leq \beta_{max}$	(68)
---	--------

$\xi_{min} \leq \sum_{g \in G} v_g \cdot \xi_g \leq \xi_{max}$	(69)
--	--------

where:

θ_m and γ_s^m Auxiliary continuous decision variables;

p_p Parameter that describes the risk aversion of the principal;

η_s^m Continuous decision variable that equals the PV of principal's costs in bidder participation scenario m and scenario s of the facilities' COD, [\$];

v_g Binary decision variable that equals 1 if point g is the optimal choice of the principal, 0 otherwise;

$n_{s,g}^m$ Parameter that corresponds to the systemic costs perceived by the principal in (m,s) if he chooses point g and, consequently, $(\zeta^g, \beta^g, \xi^g, \sigma^g)$.

The parameters $n_{s,g}^m$ are calculated offline, before solving (63)-(69) and after steps 1 and 2 of the procedure of Figure 4.2, with:

$ \begin{aligned} n_{s,g}^m &= \sum_{t=\max\{\Psi_{w(m)}^g, V_{w(m),s}-\Delta_{w(m),s}^g\}}^T \rho_{w(m)}^g \cdot h^t \\ &+ \sum_{t=\Psi_{w(m)}^g}^{V_{w(m),s}-\Delta_{w(m),s}^g-1} (a \cdot b_t - \zeta_g \cdot B) \cdot h^t \\ &- \left\{ \sum_{t=\max\{\Psi_{w(m)}^g, V_{w(m),s}-\Delta_{w(m),s}^g\}}^{V_{max}} b_t \cdot h^t + \sum_{t=V_{max}+1}^T b_t \cdot h^t \right. \\ &\quad \left. - \sum_{t=\max\{\Psi_{w(m)}^g, V_{w(m),s}-\Delta_{w(m),s}^g\}}^{D-1} \beta_g \cdot B \cdot h^t \right\} + \\ &- \sum_{t=V_{w(m),s}-\Delta_{w(m),s}^g}^{\Psi_{w(m)}^g-1} (e \cdot b_t - \xi_g \cdot B) \cdot h^t \end{aligned} $	(70)
--	--------

The first term at the right-hand side of eq. (70)⁴⁵ is the PV of payments of ρ to the transco. The second term captures the PV of differences between *ex-post costs due to delays* and penalties collected from the transco due to these delays. The third term is the PV of differences between *ex-ante avoided costs*⁴⁶ and positive incentives proportional to β paid to the transco; the fourth captures the PV of differences between the *ex-post avoided costs due to unplanned advances of the COD* and incentives proportional to ξ paid to the transco.

The objective function (63) minimizes the highest among the systemic costs for all scenarios $m \in M$ – a *minimax* approach⁴⁷. This is assumed to be the strategy of the principal to deal with uncertainty regarding bidder participation scenarios.

⁴⁵ In eq. (70), positive terms represent the PV of systemic costs, as perceived by the principal. The principal is concerned solely with monetary flows within the power sector and thus does not need to adjust any terms by taxes or charges.

⁴⁶ In eq. (70), V_{max} is the maximum among the highest values that the stochastic parameter \tilde{V}_j can assume for all transcos j . As the term $\sum_{t=V_{max}+1}^T b_t \cdot h^t$ is equal for all transcos and all possible choice of parameters of the principal, it can be removed from (21) for the optimization. The results shown in this chapter are those obtained after this term is removed, which facilitates building graphs (as the numerical values of this term are large). The reader shall bear this in mind while interpreting the results of Section 4.5.

⁴⁷ In practice, to avoid degeneracy of the problem of the principal, the term $\Lambda \cdot \sum_{g \in G} v_g \cdot (\zeta^g + \beta^g + \xi^g + \sigma^g)$, where Λ is a very small positive value (e.g., $\Lambda = 10^{-5}$), is added to the objective function. This not only avoids degeneracy and the potential problems with increased solution times that can come with it, but it also ensures that the optimal solutions displayed in Section 4.5 are these to which the lowest values of the parameters ($\zeta, \beta, \xi, \sigma$) are associated.

Constr. (64)-(65) correspond to the Rockafeller-Uryasev formulation [66] of the CVaR, applied to obtain the expected value of the costs of the principal in the $(1-p_p) \cdot |S|$ most severe scenarios of sample S . The more risk-averse the principal is, the higher is the value of the parameter p_p .

Constr. (66) ensures that the choice of g determines the value of η_s^m for all scenarios. Constraint (67) states that the principal can choose one, and only one, point g at the optimal solution. Constraints (68) and (69) impose explicit limits on β and ξ , if required.

4.5 Case studies and discussion

This section contains two case studies, to illustrate the application of the approach proposed above.

The first case study is used to analyze several aspects of the problem at hand, including the impacts of the uncertainty regarding bidder participation scenarios at the optimal solutions, the effects of practical limits on the strength of positive incentives that the principal may encounter, and variations of the optimal strategy for risk-sharing and winner selection functions due to changing levels of risk-aversion and efficiency of the agent.

The second case study offers a deeper look at how uncertainties in bidder participation scenarios may affect the solution – the reader will notice that one way to represent uncertainty regarding the efficiency and risk-aversion of the agents that may take part in the auction is to define a set J with different types of agents (regarding their risk-aversion and efficiency) and the use different subsets J_m in the problem of the principal.

4.5.1 Case study A: analyzing several aspects of the problem

The principal selects a transco to build and operate a 230-kV circuit to connect an isolated system to the main grid. Figure 4.3 shows the distribution \tilde{V} , assumed to be equal for all transcos j , and details of the dynamics of systemic costs in case A.

The isolated system is currently supplied by expensive, local thermal generation running on LNG procured at 10 \$/MMBtu under a long-term GSA (gas supply agreement), resulting in the *ex-ante avoided costs* b_t below. This GSA can only be terminated with antecedence – the principal notifies the gas supplier once the transco commits to a target COD. If the actual COD of the facilities is delayed, the LNG needed to continue operations of local plants must be procured at 16 \$/MMBtu and the *ex-post costs due to delays* will be 160% of b_t ($a=1.6$). If the circuit commences operations before the *target COD*, the principal avoids only a parcel of the LNG costs, due to a take-or-pay clause in the GSA. Thus, *ex-post avoided costs due to unplanned advances* of the COD are 80% of b_t ($e=0.8$).

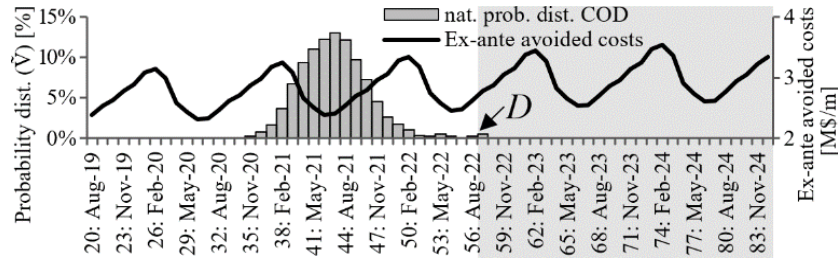

Figure 4.3. Dynamics of systemic costs; natural distribution of COD (\tilde{V}) of case A

To define the risk-sharing functions, the principal sets $B = 2.5$ M\$/month, a proxy of the average *ex-ante avoided costs* until month $t = D = 57$ (the average of the *ex-ante avoided costs* until month $t = D = 57$, rounded up to the half million). $|S| = 200$ scenarios are used in this case.

4.5.1.1 A first look at the impacts of bidder participation uncertainty

Take the case where four transcos, $J = \{A, B, C, D\}$, may take part in the competition. Their costs functions (WACC, capex, opex) are similar, except for the efficiency and risk-aversion parameters (ε_j, p_j) , which are: (0.025, 75%) for A; (0.025, 90%) for B; (0.075, 75%) for C; (0.075, 90%) for D. All agents have $\Delta_{max} = 8$. The

principal is risk-averse with $p_p = 75\%$; $\beta_{max} = \xi_{max} = 0.25$. If the principal assumes that the bidder participation scenario where *all* transcos take part in in the competition will materialize *with certainty*, he obtains the results⁴⁸ of Table 4.4.

Table 4.4. Solution: Situation with $J_M = \{A,B,C,D\}$ with Certainty

Principal's features	Principal's optimal decisions	Response of transcos				F [M\$]	CVaRp [M\$]
		j	ρ [k\$/m]	Ψ [m]	$E[\Delta X]$ [m]		
pp=75%; $\beta_{max} = 0.25$	$\zeta=0.4$; $\xi=0.25$; $\beta=0.25$; $\sigma=0.2$	A	477.9	46	1.27	61.6	47.0
		B	493.9	49	0.50	63.8	54.3
		C	478.6	47	0	61.7	54.6
		D	494.9	49	0	64.0	57.2

As expected, bidder A, who is more efficient and less risk-averse (lower-valued ε_j and p_j), wins the concession by having the lowest F . Bidder A also leads to the lowest $CVaR_p$ of the principal's losses. As also expected, Bidder A opts for a higher-powered contract (by committing to a sooner Ψ) than the other bidders.

But what if A does not take part in the bidding? How can the principal “hedge” against the possibility of A not taking part in the competition and what would this mean for the costs he perceives?

To check this, the principal considers uncertainties in bidder participation scenarios. He lets $|M| = 5$, $J_1 = \{A,B,C,D\}$, $J_2 = \{A,B,C\}$, $J_3 = \{A,B,D\}$, $J_4 = \{A,C,D\}$, and $J_5 = \{B,C,D\}$. In this case, the optimal results obtained are those of Table 4.5.

⁴⁸ $E[\Delta|X]$ denotes the expected values of $\Delta_{j,s}$ across the $(1-p_p) \cdot |S|$ most severe scenarios for the principal. $CVaR_p$ indicates the CVaR of systemic costs *for the principal*; and $CVaR_j$ indicates the CVaR of losses *for transco j*. If “m” appears as a unit in a table or a graph, it indicates “month” or “months”.

Table 4.5. Solution for Situation with Uncertainty, $|M| = 5$

Principal's features	Principal's optimal decisions	Response of transcos				F	CVaR _p
		<i>j</i>	ρ [k\$/m]	Ψ [m]	$E[\Delta X]$ [m]	[M\$]	[M\$]
$p_p=75\%$; $\beta_{max}=0.25$	$\zeta=0$; $\xi=0.25$; $\beta=0.25$; $\sigma=0$	A	472.6	47	0	64.9	53.2
		B	490.4	50	0	66.1	56.3
		C	472.6	47	0	64.9	53.2
		D	490.4	50	0	66.1	56.3

Clearly, after considering uncertainties in bidder participation scenarios, the optimal risk-sharing/winner-selection parameters now include $\zeta = 0$. This means the principal opts not to expose bidders to direct penalties in case of delays, which allows reducing the value of ρ_j bid by $j = C$. When combined, the elimination of penalties and the lower value of ρ result in a decrease of the CVaR_p in case bidder A does not participate in the competition – in this case, bidder C will be the winner. Notice that protecting against the worst-case scenario comes at the cost of increasing the CVaR_p if bidder A *does* take part in the bidding. Since now $\sigma = \zeta = 0$, bidder A now has weaker incentives to commit to a sooner Ψ and to make ex-post efforts to advance the COD, which impacts the principal's PV.

4.5.1.2 Limits to positive incentives, risk-aversion, and efficiency

The analysis of impacts of uncertainties in bidder participation scenarios will be resumed and deepened in section 4.5.2. Before that, we proceed to analyzing the effects of: practical limits to positive incentives via transfers of systemic benefits to transcos (focus on β_{max}); risk-aversions of principal and transco (p_p, p_j); and transco efficiency (ϵ_j). To isolate these analyses from the topic of uncertainty in bidder participation scenarios, we consider here the situation in which the principal is certain that only one transco will take part in the competition, and solves (51)-(54) for various combinations of $\{(\beta_{max}, p_p), (p_j, \epsilon_j)\}$. We only consider cases where the transco is at least as risk-averse

as the principal. For all analyses, $\zeta_{min} = 0.05$ and $\zeta_{max} = 0.25$. The results are show in Table 4.6.

Table 4.6. Solution for $|M|=1$ & Various Combinations of B_{MAX}, P_P, P_J, E_J

Features of principal		Features of transco		Decisions of principal				Decisions of transco		
β_{max}	p_p	p_j	ε_j	ζ	ξ	β	σ	ρ [k\$/m]	Ψ [m]	$E[\Delta X]$ [m]
0.5	50%	75%	0.25	0.15	0.05	0.5	0.175	434.4	45	1.0
0.5	50%	90%	0.25	0.15	0.05	0.5	0.075	457.4	47	0.5
0.25	50%	75%	0.25	0.35	0.05	0.25	0.25	478.4	46	0.6
0.25	50%	90%	0.25	0	0.05	0	0.175	514.2	47	0.0
0.5	75%	75%	0.25	0.15	0.05	0.5	0.175	434.4	45	2.0
0.5	75%	90%	0.25	0.15	0.05	0.5	0.075	457.4	47	0.9
0.25	75%	75%	0.25	0.4	0.25	0.25	0.225	477.9	46	1.3
0.25	75%	90%	0.25	0.35	0.05	0.25	0.15	495.1	48	0.7
0.5	50%	75%	0.75	0	0.05	0.45	0	441.0	46	0.0
0.5	50%	90%	0.75	0	0.05	0	0.175	514.2	47	0.0
0.25	50%	75%	0.75	0	0.05	0.25	0.025	471.0	46	0.0
0.25	50%	90%	0.75	0	0.05	0	0.175	514.2	47	0.0
0.5	75%	75%	0.75	0.3	0.25	0.5	0	442.1	47	0.0
0.5	75%	90%	0.75	0	0.05	0	0.125	515.1	48	0.0
0.25	75%	75%	0.75	0	0.25	0.25	0	472.6	47	0.0
0.25	75%	90%	0.75	0	0.05	0	0.125	515.1	48	0.0

Table 4.6 allows drawing some conclusions:

- (a) The principal tends to expose more efficient agents to higher incentives (via higher-valued ζ , ξ and β);

- (b) More risks tend to be allocated to less risk-averse transcos, notably when the principal himself is more risk-averse;
- (c) Positive incentives for the transco are often preferred over penalties (i.e., $\beta > \zeta$) when the principal chooses freely, but tightening practical limits to β (i.e., lowering β_{max}) leads to higher penalties when the transco is less risk-averse;
- (d) Higher-valued σ can be used to incentivize commitments to lower *target CODs*, notably when this cannot be made via β (i.e., when practical limits result in lower β_{max}).

Those are results for this simulation, where there is a single bidder and no uncertainty in participation scenarios. These are not rules of thumb that always apply, as uncertainty can lead to different results, as shown in sections 4.5.1.1 and 4.5.2.

We now look at how the choice of parameters affects the PV perceived by the agent and the transco, exploring the case with $(\beta_{max}, p_p, p_j, \varepsilon_j) = (0.25, 75\%, 90\%, 0.025)$. Table 4.6 shows that $(\zeta, \xi, \beta, \sigma) = (0.35, 0.05, 0.25, 0.15)$ for this case. Figure 4.4 shows the components of the PV of the transco and the principal, in case $V_{j,s}$ assumes values in [35,57]. Notice that, to facilitate a graphical analysis, Figure 4 shows the *gains* perceived by the transco & principal (i.e., losses multiplied by -1). Thus, more negative values are less desired by transco and principal.

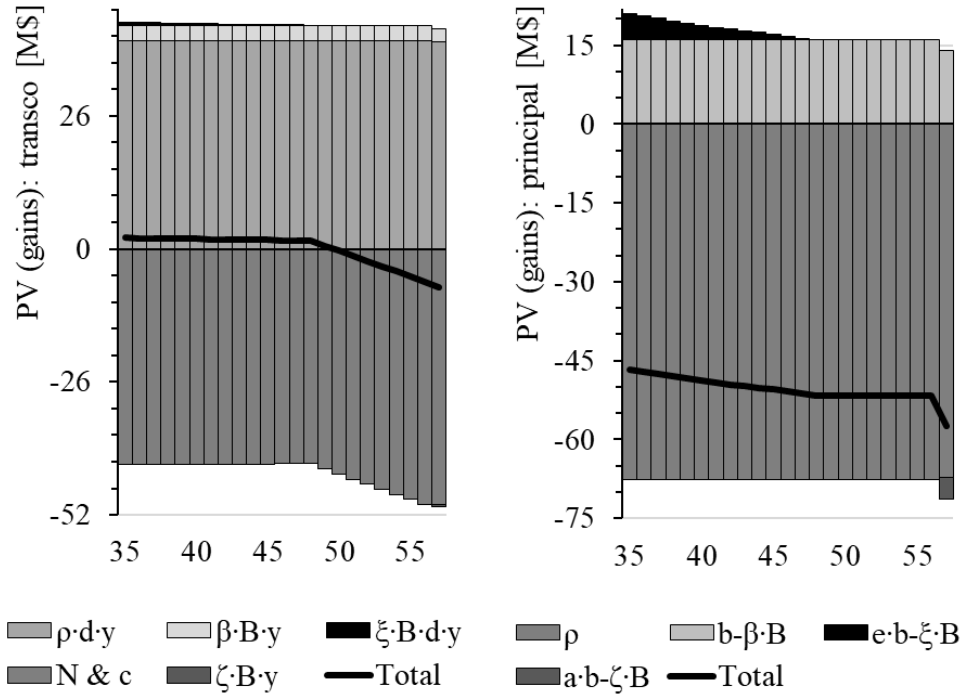

Figure 4.4. PV of gains for the transco(left) & principal(right), and their components (to which we refer using the symbols introduced in sections 4.3 and 4.4).

The horizontal threshold of the principal's PV for $48 \leq V \leq 56$ in Figure 4.4 is due to the transco making *ex-post efforts* to advance the actual COD to month 48, for the solution of $(\zeta, \xi, \beta, \sigma)$ at hand, since it committed to $\Psi = 48$ in its bid. Since the transco avoids delays, the principal's PV does not change for $48 \leq V \leq 56$. But the transco's PV varies within this range of V , as efforts to advance the CODs increase its capex. Since $\Delta_{max} = 8$ bounds the transco's efforts, there are delays if $V = 57$.

Figure 4.4 offers a partial graphical interpretation of problem (51)-(54). By solving this problem, the principal determines the shape of the function that receives $V_{j,s}$ as an input and returns the PV of the contractual relationship as an output. The interpretation is partial, as solving (51)-(54) also implicitly results in a choice of the winning transco within the competition – but it is useful and employed in Figure 4.5, to show how \tilde{V} is *converted* (see the dotted gray arrows) in the distribution probability of PVs for the transco & principal. We use the term *conversion functions* to refer to this interpretation.

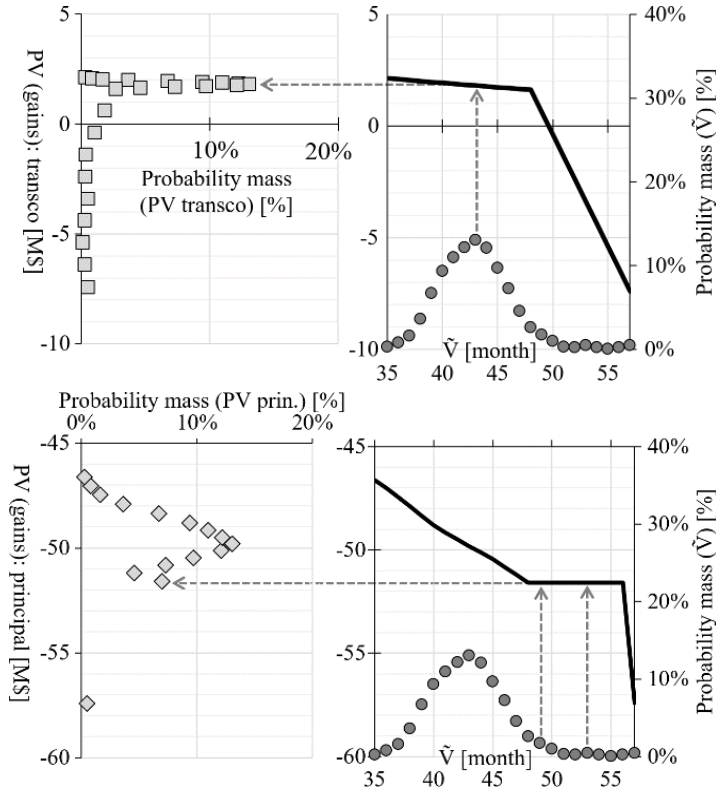

Figure 4.5. Conversion of \tilde{V} in distribution of gains: transco (above) and principal (below)

4.5.2 Case study B: a deeper look at impacts of uncertainties

The principal selects a transco to build/operate a 500-kV reinforcement. *Ex-ante avoided costs* are of 16.4 M\$/m. The *ex-post costs due to delays* are of 21.4 M\$/m and the *ex-post avoided costs due to unplanned advances of COD* are of only 3.3 M\$/m. The principal sets $B = b_t$, as b_t is constant here.

Figure 4.6 shows \tilde{V} , which is equal for all 3 transcos that may take part in the bidding. Their costs functions are similar, except for the efficiency and risk-aversion parameters, which are $(\varepsilon_j, p_j) = (0.025, 90\%)$ for $j=1$; $(0.0325, 87.5\%)$ for $j=2$; $(0.04, 78\%)$ for $j=3$. Here, $D=38$, $\zeta_{min} = 0.075$, $|S|=200$.

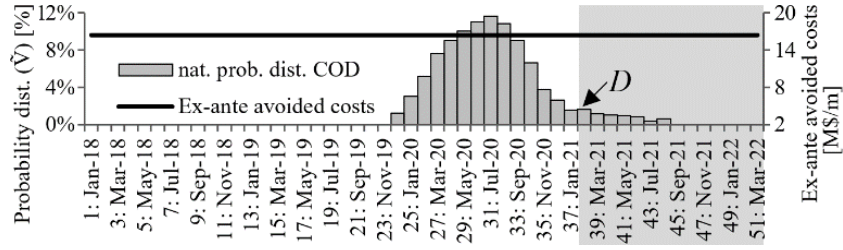

Figure 4.6. Ex-ante avoided costs (b_i); natural distribution of COD (\tilde{V}) of case B

The principal first ignores uncertainty in bidder participation scenarios, and solves (51)-(54) for $|M|=1$, $J_I=\{1,2,3\}$. Table 4.7 shows the optimal solutions, including competition results, for different values of (p_p, β_{max}) that describe the principal.

Table 4.7. Solution for $|M|=1$ & Different Combinations of B_{MAX}, P_p

Features of principal		Decisions of principal				Results of competition		Decisions of $w(m)$		
p_p	β_{max}	ζ	ξ	β	σ	$w(m)$	J_m	ρ [k\$/m]	Ψ [m]	$E[A X]$ [m]
34%	1	0.1	0.015	0.25	0.175	1	{1,2,3}	1145.8	27	4.8
34%	0.5	0.1	0.015	0.25	0.175	1	{1,2,3}	1145.8	27	4.8
34%	0	0.4	0.015	0	0.225	3	{1,2,3}	1187.2	35	0.6
78%	1	1	0.015	0.95	0	3	{1,2,3}	759.1	31	4.3
78%	0.5	0	0.015	0.4	0	1	{1,2,3}	998.9	31	4.3
78%	0	0.45	0.06	0	0.25	3	{1,2,3}	1186.1	35	1.7

We pick the case $(p_p, \beta_{max})=(78\%,1)$ for graphical analyses. Figure 4.7 shows the *conversion functions* & other results for this case. Notice that, for the solution obtained when the principal does not consider uncertainties ($|M|=1$), the conversion function of $j=3$ dominates those of the other bidders over all values of \tilde{V} .

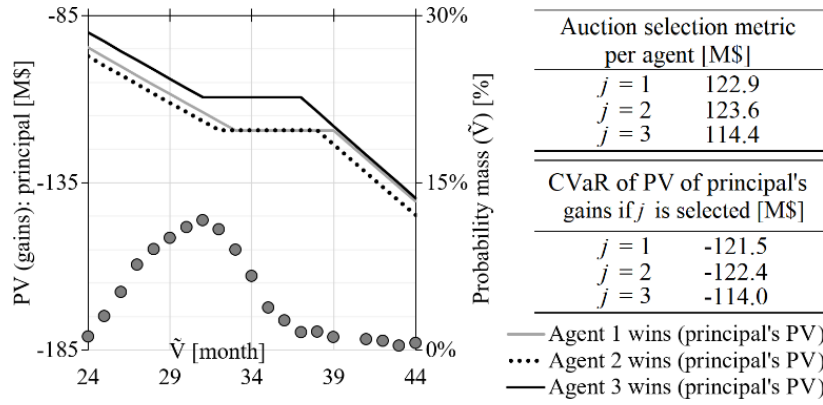

Figure 4.7. Conversion functions and other results: $|M|=1$ and $(p_p, \beta_{max})=(78\%, 1)$

The principal now considers uncertainties in scenarios m , and sets $|M|=4$, $J_1 = \{1,2,3\}$, $J_2 = \{1,2\}$, $J_3 = \{1,3\}$, $J_4 = \{2,3\}$. Solving (3)-(6), he obtains the results of Table 4.8, where \hat{m} denotes the worst-case bidder participation scenario. Comparing Tables 4.7 and 4.8 shows that, though results vary per (p_p, β_{max}) , modeling bidder participation uncertainty often resulted in: (i) values of ζ and σ decreasing and values of β increasing, and a final choice of parameters with less risks transferred to transcos; (ii) winning transcos committed to a Ψ later in the horizon (lower-power contract).

Table 4.8.: Solution for $|M|=4$ & Different Combinations of B_{MAX}, P_p

Features of principal		Decisions of principal				Results of competition		Decisions of $w(\hat{m})$		
								ρ [k\$/m]	Ψ [m]	$E[\Delta X]$ [m]
p_p	β_{max}	ζ	ξ	β	σ	$w(\hat{m})$	$J_{\hat{m}}$			
34%	1	0	0.015	0.4	0.05	1	{1,3}	993.8	30	2.5
34%	0.5	0	0.015	0.4	0.05	1	{1,3}	993.8	30	2.5
34%	0	0.05	0.015	0	0.1	2	{1,2}	1148.1	35	0.0
78%	1	0.6	0.075	1	0	1	{1,2}	745.6	32	3.7
78%	0.5	0.15	0.015	0.5	0	3	{2,3}	970.0	32	3.7
78%	0	0.4	0.015	0	0.25	1	{1,2}	1189.3	36	1.3

The results obtained for $(p_p, \beta_{max})=(78\%,1)$ are shown in Figure 4.8. As he now exposes transcos to lower-powered incentives, the principal bears higher risks. This leads to the more negative derivatives of the conversion functions for higher values of \tilde{V} .

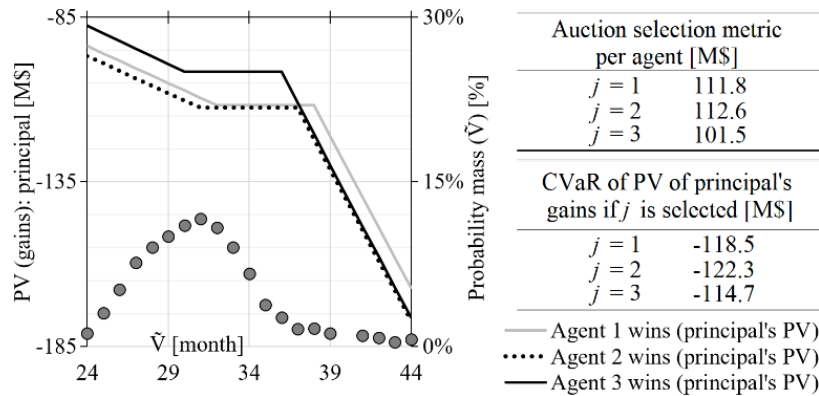

Figure 4.88. Conversion functions and other results: $|M|=4$ and $(p_p, \beta_{max})=(78\%,1)$

One may ask what would be the strategy of the principal described by $(p_p, \beta_{max})=(78\%,1)$ if he were certain that scenario $m=2$, with $J_m = \{1,2\}$, would materialize. A separate simulation shows that: (i) the optimal parameters would be $(\zeta, \xi, \beta, \sigma) = (0.45, 0.015, 1, 0)$, resulting in a higher transfer of risks to the transco; (ii) the $CVaR_p$ of the principal would be of -116.8 M\$ (1.7 M\$ better than the $CVaR_p$ for decisions under uncertainty, -118.5 M\$, showing there are costs of imperfect information).

4.6 Conclusions

We employed a MILP framework to optimally design risk-sharing/winner-selection functions, applying principal-agent theoretic concepts to selecting transcos via competition, focusing on the management of implementation time uncertainties.

Case studies show that the possibility of letting the transco commit to a *target COD* as part of the bidding process offers these agents the possibility of implicitly

choosing among stronger and weaker incentives, since the penalties and positive incentives applied to the transco depend on differences between the actual COD of the facilities and the target COD specified in the contract. The interpretation of the choice of a target COD by the agent as a choice among weaker or stronger incentives is corroborated by the result that, if other conditions are kept unchanged, more efficient transcos choose target CODs sooner in the horizon – this is analogous to results of classical references, as [62], which focus on instances of the principal-agent problem in which the agent chooses from different combinations of a fixed remuneration component and a reimbursement that closely matches its actual incurred costs.

The indication of potential benefits of letting transcos commit to a contractual target COD as part of their bids in competitive process should be a topic of attention to regulators in several jurisdictions that face problems with implementation delays. This mechanism, when used harmoniously with the other proposals of this chapter, may help revealing the true efficiency of transmission companies regarding implementation and lead to lower systemic costs of the transmission implementation process. As showed here, the possibilities of using this mechanism properly depend, to a certain extent, on the ability of the regulator to also adjust risk-sharing mechanisms. Even though some regulators may face practical limitations to making such adjustments by controlling positive incentives, the simulations show that, when these practical limitations exist, controlling the level of negative incentives is a feasible strategy. Since negative incentives are already used in most jurisdictions, as mentioned in section 4.1, adjusting their level may be a feasible action for some regulators. Even if currently used negative incentives mechanism most commonly define penalties as a function of the remuneration due to the transco (rather than systemic costs of delays), the adjustment of the *level* of these penalties represents a feasible choice for many regulators. This means that adopting the qualitative recommendations that arise from these conclusions may be a feasible choice in some jurisdictions, as an improvement to a winner-selection and risk-sharing mechanism that already exist.

The analyses show that, as expected, the principal allocates more risks to less risk-averse transcos, notably when the principal himself is more risk-averse. Positive incentives are often preferred over penalties when the principal is free to choose, but practical limits to transferring systemic benefits to agents can lead to higher reliance on penalties. Placing higher weights on the target COD declared by the agent as part of the bidding process can also be a valuable strategy when there are practical limits to such transfers of systemic benefits to agents.

A brief comment on positive incentives is in order at this point. Currently, negative incentives are much more common in practice than positive ones – and, in jurisdictions where positive incentives are indeed used, their monetary levels are commonly lower than those of penalties. The results show that, from a theoretical point of view, this is often not the globally optimal solution. Nonetheless, the results also indicate that, even when there are practical limitations to positive incentives, managing uncertainties in implementation times is still possible via a combination of the strategies indicated in this chapter.

When uncertainties on classes of transcos (defined by similar risk-aversions, efficiencies to counter-act sources of delays found *ex-post*) exist, the principal often prefers to allocate less risks to transcos (in comparison with simulations where such uncertainties don't exist).

The simulations also show that, when uncertainties regarding which companies will participate in the competitive bidding process exist, the principal perceives the costs of imperfect information, by choosing the parameters of the winner-selection and risk-sharing functions that are lead to comparatively worse results, in comparison to the case where the principal could make a decision under certainty regarding the participants in the competitive bidding process. This often results in the choice of “milder” incentives to the transmission agent. While this result is easy to understand, it is worth recalling it also matches the qualitative conclusions of canonical works on Principal-Agent Theory [62].

Possible future extensions of the work are presented in chapter 5, section 5.3.2.

5 SUMMARY OF CONCLUSIONS AND POSSIBLE FUTURE EXTENSIONS OF THE WORK

This chapter presents a summary of the conclusions, merely summarizing the conclusions already presented in each of the chapters 2 to 4, and then proceeds to presenting possible future extensions of the work:

- Section 5.1 does that for the topic approached in chapter 2, referring to combinatorial and simultaneous descending auctions for transmission concessions;
- Section 5.2 does that for the topic approached in chapter 3, referring to transmission expansion planning under consideration of uncertainties in facility implementation times
- Section 5.3 does that for the topic approached in chapter 4, referring to the management of uncertainties in implementation times of competitively-procured transmission via optimally designed risk-sharing and winner selection functions.

5.1 Combinatorial and simultaneous descending auctions for transmission concessions

5.1.1 Summary of main conclusions

In chapter 2 of this document, we proposed the application of combinatorial and simultaneous descending auctions (CA and SDA) for transmission concessions, and successfully employed the simulation framework developed for this thesis to case studies to assess potential benefits of using these auction protocols in the context of electricity transmission.

The analyses suggest there can be potential benefits in using the CA or SDA protocols in transmission auctions to award transmission concessions, in substitution to sequential auction protocols prevailing in jurisdictions such as Latin America. This can facilitate the consideration of complementarities between sets of transmission facilities by auction participants, resulting in benefits to the bidders themselves and to the grid users paying charges to cover the revenues required to remunerate the transmission system.

The simulation framework was used for case studies built with realistic data, and for all of them the CA and SDA protocols outperformed the SA regarding treatment of the exposure problem. It was shown that: (i) the SA is outperformed by the CA and the SDA in its ability to treat the exposure problem; and (ii) the CA outperforms the SDA with respect to the same criterion.

The analyses also hint at the potential impacts on revenues to be collected from transmission grid users if second-price rules (Vickrey pricing for SA, VCG for the CA) are employed, after the solution of the winner selection problem, to determine the revenue requirements (RR) to which auction winners will be entitled. Impacts on RR are of more than 10% in some cases. Though second-price rules present important advantages over first-price rules, such as incentivizing agents to present bids equal to their actual private estimates of the RRs to explore the transmission concessions, regulators and policymaker may in practice encounter some practical resistance to implementing them, due to such impacts on RR.

We believe that the quantitative results obtained for the realistic case studies indicate that the possibility of changing the protocols in auctions to award transmission concessions (from sequential auctions to combinatorial or simultaneous descending auctions) merits attention and may represent a topic to be considered by regulators and system planners.

5.1.2 Possible future extensions of the work

Possible future extensions of the work include:

- Extending the simulation models used in chapter 2 to account for strategic behavior of bidders and the ability of the auction protocols to mitigate strategic manipulations – equilibrium models are among the alternatives to account for strategic behavior.
- Extending the analyses to assess other features of the auction protocols – for example, costs of participation and deterrence of entry of smaller players.
- Extending the analyses to evaluate the possibility of employing combinatorial and simultaneous auction protocols in the cases where other competitive bidding models are used – for instance, the *needs-based* model mentioned in section 2.6.
- Using a similar approach to investigate possible benefits of combinatorial auctions to award power purchase agreements to generation projects.

5.2 Transmission expansion planning under consideration of uncertainties in facility implementation times

5.2.1 Summary of main conclusions

In chapter 3 of this document, we proposed an optimization approach to transmission expansion planning under explicit consideration of uncertainties in the implementation times of transmission facilities. Under this approach, planners decide on the nature of the facilities to be included in the plan and on dates at which their implementation is scheduled to start, but the action times at which the facilities will commence commercial operations is uncertain, since this will be given by the sum of

the implementation start date (deterministic decision) and an uncertain implementation time period. The proposed approach was applied to a case study.

First, the implementation start dates defined by the planner in a benchmark situation where no uncertainties in implementation times are considered, and each facility is assumed to be implemented within a time span corresponding to the most probable implementation time, differ significantly from those of the cases where this uncertainty is explicitly taken into account.

Even in a case study when only “mild” uncertainties in implementation times were assumed (that would correspond to less significant delays than those seen in Brazil in recent years), the planner would opt for significant advancements of the implementation start dates, with respect to the benchmark situation with no delays.

However, the advancements do not always correspond to the difference between the maximum possible value of the probability distribution and its mode. This illustrates that, while the optimal strategy for the planner does *not* necessarily include considering the mode (or the average value rounded to the closest integer) of the probability distribution of implementation times while determining the implementation start date, it *does not* necessarily involve being extremely conservative and considering the extreme value of the probability distribution for every circuit either.

Another relevant finding is that the advancements of the implementation start dates (again, with respect to the benchmark situation where no delays are considered) depend not only on the probability of implementation times that are inherent to the facilities, but also to their impacts on the operation of the power system. This was illustrated by fact that two different facilities that had the same probability distributions of implementation times were subject to different advancements (one of them by 2 stages, the other by only 1 stage) in the case study.

A second relevant finding is that, since the proposed methodology relies on using a sample of scenarios of implementation times within a mixed-integer linear program, sample variance can thus be an important issue in this problem, and increasing the size of the sample can significantly increase computational burden. Though increasing

the computational burden is not as critical in an expansion planning application as, say, in a system operation application, the issue merits attention.

Finally, it is worth stressing that we provide an example of how to estimate the probability distribution of implementation times of transmission facilities with aid of statistical treatment of historical data on Appendix B of this document.

5.2.2 Possible future extensions of work

The discussion of the previous section already alluded to an important possible extension of the work regarding the topic of this chapter: the issue of sample variance and the possibility of using specialized sampling techniques to lower the computational burden required for the simulations. This analysis should ideally be accompanied by the investigation of convergence of proposed methodology, in what concerns the planning decisions, with respect to the size of the sample of scenarios of implementation times. Possible specialized sampling techniques to be investigated include importance sampling [68]-[69]. It is worth mentioning that the fact that the uncertainties of interest impact the time of actual realization of discrete decisions about the construction of candidate facilities is expected to represent an additional complexity for the use of importance sampling techniques. For instance, since these facilities are not present in the system considered before the solution of the optimization problem is known, the practice of simulating various scenarios of operation of the system at hand before the solution of the optimization problem and selecting the scenarios that are expected to most impact the objective function cannot be used without adjustments.

The possible topics for future work also include the execution of case studies for larger systems. These case studies are expected to allow the investigation of other features of the proposed methodology and even the investigation of some basic properties of the problem of transmission system expansion under explicit consideration of uncertainties in implementation times. For instance, the explicit consideration of this class of uncertainties is expected to potentially affect not only the schedule the

candidates included in the plan (*when* to start implementation), but also the nature of these candidates (*what* to build).

Other possible topics for investigation include: (i) the possible effects of expanding the planning horizon, to better account for the fact that the a decision to change the *nature* of the candidates included in the final expansion plan, for example by including additional candidates, represents additional capital expenses that impact the system for a long time, and may not be justifiable if a larger planning horizon is considered; and (ii) the possibility to include in the problem a mathematical treatment of the dependency between implementation delays and cost-overruns during the implementation stage of the transmission facilities that may increase the value of the capital expenses and, consequently, the “annuities” considered as cost components in the models. The possibility of applying the framework develop to represent uncertainties in implementation times of transmission facilities within a robust optimization approach is also a possible topic for future research.

5.3 Management of uncertainties in implementation times of competitively-procured transmission via optimally designed risk-sharing and winner selection functions

5.3.1 Summary of main conclusions

In chapter 4 of this thesis, we developed and employed a mixed-integer linear framework to optimally design risk-sharing and winner-selection functions in the context of auctions to select agents to implement and operate transmission facilities. In a simple explanation: (i) *winner selection functions* are mechanisms a planner/regulator uses to select the winner of the auctions; and (ii) *risk-sharing functions* are positive monetary incentives or penalties a planner/regulator uses to incentivize the agents that win the auctions to implement the facilities in time, or even advance their commercial operations date (COD), and to penalize implementation delays with respect to a target

COD specified in the concession contract. Penalties can be seen as a way to share part of the risks of costs of delays to the system with the transmission concessionaire, and positive incentives can be seen as a way to share part of the benefits of eventual advancements of the COD of the facilities with the transco – hence the expression *risk-sharing*.

The developed approach applies concepts of the principal-agent theory to the context of electricity transmission auctions, when uncertainty in implementation times and on the ability and efficiency of transmission concessionaires with deal with issues arising in the implementation of facilities are topics that merit attention.

Case studies show that the possibility of letting the transco commit to a *target COD* as part of the bidding process offers these agents the possibility of implicitly choosing among stronger and weaker incentives, since the penalties and positive incentives applied to the transco depend on differences between the actual COD of the facilities and the target COD specified in the contract. The possibility of choice by the transco, along with the optimal design of the winner-selection function and of incentives by the planner/regulator, results in lower systemic costs of implementation of the transmission facilities. Basically speaking: (i) the transcos are implicitly given a *menu* of contracts, as they can choose between contracts with higher or lower incentives by simply selecting the target COD to which they will commit; and (ii) each type of transco (one that can deal with challenges in implementation of facilities in a more or in a less efficient way, one that is more or less risk-averse), while selecting the contract that is best fit to its own efficiency and risk-averseness, also implicit selects a type that is “best for the system”.

We show that there are ways for the planner/regulator do this in an optimal way, by using a mixed-integer framework to put concepts of the principal-agent theory in practice.

Hence, the indication of potential benefits of letting transcos commit to a contractual target COD as part of their bids in competitive process should be a topic of attention to regulators in several jurisdictions that face problems with implementation

delays. Even though some regulators may face practical limitations to making such adjustments by controlling positive incentives, the simulations show that, when these practical limitations exist, controlling the level of negative incentives is a feasible strategy. Since negative incentives are already used in most jurisdictions, adjusting their level may be a feasible action for some regulators.

The analyses show that, as expected, the principal allocates more risks to less risk-averse transcos, notably when the principal himself is more risk-averse. Positive incentives are often preferred over penalties when the principal is free to choose, but practical limits to transferring systemic benefits to agents can lead to higher reliance on penalties. Placing higher weights on the target COD declared by the agent as part of the bidding process can also be a valuable strategy when there are practical limits to such transfers of systemic benefits to agents.

The simulations also show that, when uncertainties regarding which companies will participate in the competitive bidding process exist, the principal perceives the costs of imperfect information, by choosing the parameters of the winner-selection and risk-sharing functions that lead to comparatively worse results, in comparison to the case where the principal could make a decision under certainty regarding the participants in the competitive bidding process. This often results in the choice of “milder” incentives to the transmission agent.

5.3.2 Possible future extensions of the work

Possible future extensions of the work include:

- Extending the approach to situations where the simplifying assumption that competition is high enough to ensure that the best bid from each class of transcos strictly recovers costs (including capital remuneration costs) does not hold.

- Extending the approach to the situation where the principal also faces uncertainties on the systemic costs of the absence of transmission facilities.
- Seeking alternatives to formulate the problem as a single multi-level mathematical programming problem. Among the possible strategies for that, is the possibility of using the equality $\sum_{t=L}^U r^t = (r^L - r^{U+1}) / (1 - r)$, for $r < 1$, to obtain a non-linear formulation of the problem, in substitution to the current mixed-integer linear programming formulation.
- Using other models of risk-aversion of the principal and the transco; and/or using approaches for decision-making under uncertainty regarding bidder participation scenarios other than the *minimax* approach currently employed here.
- Using a similar approach to manage uncertainties in implementation times in the case of new generation projects, when competitive bidding processes are used to select agents to which energy contracts are awarded.

REFERENCES

[1] ANEEL (Brazil), “Editais de Transmissão”, available online at <http://www.aneel.gov.br>, retrieved Jan. 2016.

[2] CDEC-SIC (Chile), “Licitaciones Troncales”, available online at <http://www.cdecsic.cl>, retrieved in Jan. 2016.

[3] CDED-SING (Chile), “Licitaciones Sistema de Transmisión Troncal”, available online at <http://cdec2.cdec-sing.cl>, retrieved Jan. 2016.

[4] UPME (Colombia), “Proyectos – Convocatorias UPME”, available online at <http://www1.upme.gov.co>, retrieved Jan. 2016.

[5] ProInversión (Peru), “Electricidad – Proyectos Encargados – Adjudicados”, available online at <http://www.proyectosapp.pe>, retrieved Jan. 2016.

[6] Secretaria de Energia (Mexico), “DECRETO por el que se expiden la Ley de la Industria Eléctrica, la Ley de Energía Geotérmica y se adicionan y reforman diversas disposiciones de la Ley de Aguas Nacionales”, Aug. 2014.

[7] FERC (USA), “Order No. 1000-B Transmission Planning and Cost Allocation by Transmission Owning and Operating Public Utilities”, Oct. 2012.

[8] AESP (Canada), “Competitive Process for Critical Transmission Infrastructure – Recommendation Paper”, Jun. 2011.

[9] AESP (Canada), “Amendments to the Competitive Process Recommendation Paper”, Jun. 2011.

[10] Ontario Energy Board (Canada), “EB-2011-0140 - Phase 1 Decision and Order”, Jul. 2012.

[11] ProInversión (Peru), “Las APP en Peru”, available online at <http://www.proyectosapp.pe>, retrieved Jan. 2016.\

[12] I. Rodríguez, “En 2016, primera licitación para líneas de transmisión eléctrica”, *in* La Jornada (newspaper), 22 December 2015.

- [13] P. Cramton, “Simultaneous ascending auctions”, in *Wiley Encyclopedia of OR & MS*, 2004.
- [14] S. De Vries, R. V. Vohra, "Combinatorial auctions: A survey", in *INFORMS Journal on Computing*, v. 15, 2003.
- [15] E. Rodrigues, “62% das linhas de transmissão em andamento no país estão em atraso, diz Aneel”, *in* Estado de São Paulo (newspaper), 4 January 2016.
- [16] H. Vargas, “Nuevas líneas de transmisión eléctrica promedian retraso de 18 meses”, *in* La Segunda (newspaper), 18 June 2012.
- [17] “ISA manifiesta preocupación por el retraso de Polpaico - Cardones”, *in* Electricidad (online newspaper), dated 1 December 2015, available online at <http://www.revistaei.cl/>, retrieved Jan. 2016.
- [18] “Cables cruzados”, *in* Dinero (online newspaper), dated 30 May 2013, available online at <http://www.dinero.com/>, retrieved Jan. 2016.
- [19] Osinergmin (Peru). “Contratos de Concesión y Ampliaciones de Líneas de Transmisión Eléctrica ‘en Construcción’”, Dec. 2015.
- [20] Edison Electric Institute, “Transmission Projects: at a Glance”, Mar. 2013.
- [21] B. Sovacool, A. Gilbert, & D. Nugent, “Risk, Innovation, electricity infrastructure and construction cost overruns: Testing six hypotheses”, *in* Energy, vol. 74, pp. 906-971, Sep. 2014.
- [22] P. Cramton, “The Efficiency of the FCC Spectrum Auctions”, in *Journal of Law and Economics*, 1998.
- [23] P. Klemperer, *Auctions: Theory and practice*, Princeton University Press, 2004.
- [24] S. Lumbreras, A. Ramos, “The new challenges to transmission expansion planning – Survey of recent practice and literature review”, *Electric Power Systems Research*, to appear in vol. 134, pp. 19-29, issue May. 2016.
- [25] J. J. Laffont, D. Martimort, *The theory of incentives: the principal-agent model*. Princeton university press, 2009.

[26] R. Ferreira, C. Borges, L. A. Barroso. "Combinatorial and simultaneous descending auctions for electricity transmission concessions", to appear in IEEE Transactions on Power Systems, accepted for publication in 2017.

[27] R. Ferreira, C. Borges, L. A. Barroso. "*Managing uncertainty in implementation times of competitively-procured transmission via risk-sharing and winner selection functions*", submitted to IEEE Transactions on Power Systems in November 2017

[28] R. Ferreira, H. Rudnick, L. Barroso, "The Expansion of Transmission: The Challenges Faced in South America", IEEE P.E.Mag., July 2016.

[29] J. P. Buechler, "Order 1000 Implementation in the United States", IEEE Power and Energy Society General Meeting 2016, July 2016.

[30] J. Pfeifenberger, "Emerging Business Models for Non-Incumbent Transmission Projects", 18th Annual INFOCAST Transmission Summit 2015, March 2015.

[31] S. de Vries, R. V. Vohra, "Combinatorial auctions: A survey", in INFORMS Journal on Computing, v. 15, 2003.

[32] P. Cramton, "Simultaneous ascending auctions", in Wiley Encyclopedia of OR & MS, 2004.

[33] P. Milgrom, "Putting auction theory to work: The simultaneous ascending auction" Journal of political economy 108.2, 2000.

[34] C. Yi, J. Cai, "Multi-Item Spectrum Auction for Recall-Based Cognitive Radio Networks with Multiple Heterogeneous Secondary Users," in IEEE Transactions on Vehicular Technology, vol. 64, no. 2, Feb. 2015.

[35] L. Barroso, A. Street, S. Granville, M. Pereira, "Offering Strategies and Simulation of Multi-Item Iterative Auctions of Energy Contracts," in IEEE Transactions on Power Systems, vol. 26, no. 4, Nov. 2011.

[36] L. T. A. Maurer, L. A. Barroso, "Electricity Auctions: An Overview of Efficient Practices", The World Bank Press, 2011.

- [37] Vickrey, W. “Counterspeculation, Auctions, and Competitive Sealed Tenders”, in *J. of Finance*, v.16, 1961.
- [38] Groves, T. “Incentives in Teams”, in *Econometrica*, vol. 41, no. 4, 1973.
- [39] D. Mishra, D. C. Parkes, “Ascending price Vickrey auctions for general valuations”, *Journal of Economic Theory*, 132(1), pp. 335-366, 2007.
- [40] S. de Vries, J. Schummer, R. V. Vohra, “On ascending Vickrey auctions for heterogeneous objects”, *Journal of Economic Theory*, 132(1), pp. 95-118, 2007.
- [41] L. M. Ausubel, “An efficient dynamic auction for heterogeneous commodities”, *The American Economic Review*, 96(3), 2006.
- [42] L. M. Ausubel, P. R. Milgrom, “Ascending Auctions with Package Bidding”, *Frontiers of Theoretical Economics*, 1(1), pp. 1–42, 2002
- [43] P. Klemperer, “What really matters in auction design”, *The Journal of Economic Perspectives*, 16(1), pp. 169-189, 2002.
- [44] Hemmati, R., Hooshmand, R. A., & Khodabakhshian, A. (2013). State-of-the-art of transmission expansion planning: Comprehensive review. *Renewable and Sustainable Energy Reviews*, 23, 312-319.
- [45] G. Latorre, R. D. Cruz, J. M. Areiza, & A. Villegas, “Classification of publications and models on transmission expansion planning”, *IEEE Transactions on Power Systems*, 18(2), 938-946, 2003.
- [46] B. Chen, J. Wang, L. Wang, Y. He, Z. Wang, "Robust optimization for transmission expansion planning: Minimax cost vs. minimax regret." *IEEE Transactions on Power Systems* 29, no. 6, 3069-3077, 2014.
- [47] A. Moreira, G. Strbac, R. Moreno, A. Street, I. Konstantelos, “A Five-Level MILP Model for Flexible Transmission Network Planning Under Uncertainty: A Min–Max Regret Approach”, *IEEE Transactions on Power Systems*, 33(1), 486-501, 2018.
- [48] S., Binato, M. V. F. Pereira, S. Granville, “A new Benders decomposition approach to solve power transmission network design problems”, *IEEE Transactions on Power Systems*, 16(2), 235-240, 2001.

- [49] A. Moreira, A. Street, J. M. Arroyo. "An adjustable robust optimization approach for contingency-constrained transmission expansion planning" IEEE Transactions on Power Systems, 30.4, 2013-2022, 2015.
- [50] University of Washington, "Power System Test Case Archive – 14 Bus", available online https://www2.ee.washington.edu/research/pstca/pf14/pg_tca14bus.htm, retrieved Oct. 2016.
- [51] W. Freire (Canal Energia), "Atraso em transmissão exigirá contratação de térmicas em Roraima", Jun. 2016.
- [52] ANEEL, "Draft Concession Contract for Tender #05/2016", Mar. 2017.
- [53] Comisión Nacional de Energía, "Resolución Extenta nº 364", Jul. 2015.
- [54] Ontario Energy Board, "East-West Tie Line Designation", Aug. 2013.
- [55] CAISO, "Gates-Gregg Project Sponsor Selection Report", Nov. 2013.
- [56] P. Bolton, M. Dewatripont, *Contract Theory*, MIT Press, 2005.
- [57] J. Laffont, J. Tirole. *A theory of incentives in procurement and regulation*. MIT Press, 1993.
- [58] P. Agrell, P. Bogetoft, J. Tind; "DEA and dynamic yardstick competition in Scandinavian elec. distribution"; J. Productivity Analysis, 23.2, 2005.
- [59] I. Vogelsang; "Electricity transmission pricing and performance-based regulation"; The Energy Journal, 2006.
- [60] J. Rosellón, H. Weigt, "A dynamic incentive mechanism for transmission expansion in electricity networks: Theory, modeling, and application"; The Energy Journal, p. 119-148, 2011.
- [61] P. Joskow, "Incentive regulation in theory and practice: electricity distribution and transmission networks", In: Economic Regulation and Its Reform: What Have We Learned?; U. Chicago Press, pp. 291-344, 2014.
- [62] J. Laffont, J. Tirole. "Auctioning incentive contracts", Journal of Political Economy, 95.5, pp. 921-937, 1987.

[63] J. Molina, J. Contreras, H. Rudnick; “A principal-agent approach to transmission expansion Part I: regulatory framework”; IEEE Transactions on Power Systems, v. 28, n. 1, p. 256-263, 2013.

[64] B. Gorenstin, N. Campadonico, J. Costat, M. Pereira, "Power system expansion under uncertainty ", IEEE Trans. Pow. Sys., Feb. 1993.

[65] A. N. Halter, G. W. Dean, "Decision under uncertainty", South-Western Publishing Co. 1971.

[66] R. Rockafeller, S. Uryasev, “Conditional value-at-risk: optimization approach”, Applied Optimization, v. 54, pp. 411-435.

[67] G. Nemhauser, L Wolsey. Integer programming and combinatorial optimization, Wiley-Interscience, 1999.

[68] P. W. Glynn, D. L. Iglehart, D.L., “Importance sampling for stochastic simulations”, *in* Management Science, vol. 35, issue 11, pp. 1367-1392, 1989.

[69] W. H. Press, S. A. Teukolsky, W. T. Vetterling, B. P. Flannery, "Section 7.9.1 Importance Sampling", *in* Numerical Recipes: The Art of Scientific Computing, 2007.

[70] ANEEL-SFE, “Acompanhamento dos Empreendimentos de Transmissão”, Nov. 2017.

[71] Hill, P. D. “Kernel estimation of a distribution function.” Communications in Statistics - Theory and Methods. Vol 14, Issue. 3, 1985, pp. 605-620.

6 APPENDIX A: COMBINATORIAL AUCTION AS TOOL TO SELECT EXPANSION CANDIDATES

In section 2.6, we commented on a possible use of combinatorial auctions that was not investigated in the main body of text of this thesis.

Combinatorial auctions for transmission assets could be used as a tool to select, among various candidate transmission facilities of an expansion plan that are “offered” in the auction, those that should be part of the final expansion plan. This approach combines auction theory with transmission expansion planning, by considering various candidate facilities as items in an auction and using a winner selection function that takes full account of the dynamics of power system expansion and operation costs. Not all of the candidates offered as items in the auction will be ultimately built – the winner selection function will take care of determining which candidates are ultimately built. The resulting auction protocol may be too complex to use in practice, but applying it offers some interesting insight on how auctions can be used to reveal information that is useful for expansion planning, and how planning can benefit from acquiring more accurate information on costs and on implementation times.

This appendix presents an example of this application.

6.1 Problem setup and methodology

We present a case study aiming at illustrating the possibility of using auctions as a tool for acquiring information relevant to select candidates in a transmission expansion plan. We assume that the relevant information to be acquired regards not only the revenues required to implement and operate the transmission facilities, but also the dates at which the competitors believe they would be able to actually put the facilities in commercial operation. For this, it will be assumed here that transmission companies competing in the auction will reveal their private information on the dates that they

believe is feasible to put the facilities into operation. This is a simplifying assumption, and clearly chapter 4 of the main body of text indicates the complexity of designing mechanisms that aid in the revelation of such information.

The reader should bear these caveats in mind while assessing the remainder of this section. The case study may, however, offer important insight on why it is desirable to use the auction to acquire information on the actual CODs that the transmission companies believe to be feasible.

The problem setup to be considered here is characterized as follows:

- The regulator/auctioneer holds a transmission auction in which winners are selected not only based on the values of annual revenues they require to operate transmission concessions, but also on the contractual CODs to which they will commit to put the facilities in operation.
- The auction winners are selected via the evaluation of the bids within an optimization model that includes a full modelling of the bids and their impacts on system operation costs. Such a winner selection process may be perceived as too complex for practical use, but it serves the purposes of this preliminary case study.
- A combinatorial auction protocol is used. The focus will be solely on the selection of winners, and not on the pricing of bids – this means that no VCG pricing protocol will be simulated.

The formulation of this illustrative problem basically combines that of the combinatorial auction protocol presented in chapter 2 with that transmission expansion planning under consideration of uncertainties in implementation delays of chapter 3 (but considering a simplified version of the approach of chapter 3). The formulation is presented in the following:

$\min \left\{ \sum_{t \in T} u^t \cdot \left\{ \sum_{j \in J_{DD}} \left[\sum_{\{t \in T t \leq t\}} \left(\sum_{n \in N} \sum_{p_n \in P_n} b_{p_n}^j \cdot a_{p_n}^{j,t} \cdot u_{p_n} \right) \right] \right\} + \right. \\ \left. \sum_{t \in T} u^t \cdot \left\{ \sum_{s_d \in S_d} p_{s_d} \cdot \left\{ \sum_{s_\sigma \in S_\sigma} p_{s_\sigma, t} \cdot \left[\left(\sum_{k \in K} \gamma_{k, s_d, s_\sigma, t} \cdot h_t \cdot c_{k, s_\sigma, t} \right) + \right. \right. \right. \right. \\ \left. \left. \left. \left(\sum_{i \in I} \sigma_{i, s_d, s_\sigma, t} \cdot h_t \cdot c_{LSH, i, t} \right) \right] \right\} \right\} \right\}$	(71)
--	------

subject to

$\sum_{n \in N} \sum_{p_n \in P_n} \left[\left(\sum_{t \in T} a_{p_n}^{j,t} \right) \cdot u_{p_n} \right] \leq 1 \quad ; \forall j \in J_{DD}$	(72)
--	------

$\sum_{p_n \in P_n} u_{p_n} \leq 1 \quad ; \forall n \in N$	(73)
---	------

$\theta_{iREF, s_\sigma, t} = 0 \quad ; \forall s_\sigma \in S_\sigma, t \in T$	(74)
---	------

$\left(\sum_{\{k \in K BUS(k)=i\}} \gamma_{k, s_\sigma, t} \right) + \left(\sum_{\{j \in J BTO(j)=i\}} \varphi_{j, s_\sigma, t} \right) = \\ \left(\sum_{\{j \in J BFR(j)=i\}} \varphi_{j, s_\sigma, t} \right) + \left(d_{i, s_\sigma, t} - \sigma_{i, s_\sigma, t} \right) \\ ; \forall i \in I, s_\sigma \in S_\sigma, t \in T$	(75)
--	------

$\sigma_{i, s_\sigma, t} \leq d_{i, s_\sigma, t} \quad ; \forall i \in I, s_\sigma \in S_\sigma, t \in T$	(76)
---	------

$\underline{g}_{k, s_\sigma, t} \leq \gamma_{k, s_\sigma, t} \leq \bar{g}_{k, s_\sigma, t} \quad ; \forall k \in K_t, s_\sigma \in S_\sigma, t \in T$	(77)
---	------

$\varphi_{j, s_d, s_\sigma, t} = y_j \cdot \left(\theta_{BFR(j), s_\sigma, t} - \theta_{BTO(j), s_\sigma, t} \right) \quad ; \forall j \in J_{EX, t}, s_\sigma \in S_\sigma, t \in T$	(78)
--	------

$\varphi_{j, s_\sigma, t} - y_j \cdot \left(\theta_{BFR(j), s_\sigma, t} - \theta_{BTO(j), s_\sigma, t} \right) \leq \\ M_j \cdot \left\{ 1 - \left[\sum_{\{t \in T t \leq t\}} \left(\sum_{n \in N} \sum_{p_n \in P_n} a_{p_n}^{j,t} \cdot u_{p_n} \right) \right] \right\} \\ ; \forall j \in J_{DD}, s_\sigma \in S_\sigma, t \in T$	(79)
--	------

$-M_j \cdot \left\{ 1 - \left[\sum_{\{t \in T t \leq t\}} \left(\sum_{n \in N} \sum_{p_n \in P_n} a_{p_n}^{j,t} \cdot u_{p_n} \right) \right] \right\} \leq \\ \varphi_{j, s_\sigma, t} - y_j \cdot \left(\theta_{BFR(j), s_\sigma, t} - \theta_{BTO(j), s_\sigma, t} \right) \\ ; \forall j \in J_{DD}, s_\sigma \in S_\sigma, t \in T$	(80)
---	------

$-\bar{f}_j \leq \varphi_{j, s_\sigma, t} \leq \bar{f}_j \quad ; \forall j \in J_{EX}, s_\sigma \in S_\sigma, t \in T$	(81)
--	------

$\varphi_{j, s_\sigma, t} \leq \bar{f}_{j, s_\sigma, t} \cdot \left[\sum_{\{t \in T t \leq t\}} \left(\sum_{n \in N} \sum_{p_n \in P_n} a_{p_n}^{j,t} \cdot u_{p_n} \right) \right] \\ ; \forall j \in J_{DD}, s_\sigma \in S_\sigma, t \in T$	(82)
--	------

$-\underline{f}_{j, s_\sigma, t} \cdot \left[\sum_{\{t \in T t \leq t\}} \left(\sum_{n \in N} \sum_{p_n \in P_n} a_{p_n}^{j,t} \cdot u_{p_n} \right) \right] \leq \varphi_{j, s_\sigma, t} \\ ; \forall j \in J_{DD}, s_\sigma \in S_\sigma, t \in T$	(83)
---	------

where:

$a_{p_n}^{j,t}$ Binary parameter that describes the package p_n bid by bidder n . This parameter will equal 1 if item j is part of the package p_n and the contractual COD determined by the bidder for this item corresponds to stage t ; and the parameter will be 0 otherwise⁴⁹;

$b_{p_n}^j$ Parameters that describes the annual revenue required by bidder n for the facility j in package p_n [\\$]⁵⁰.

All other parameters and decision variables have similar meanings to those used in the definition of the problems of chapters 2 and 3. In fact, the structure of the problem (71)-(83) above is very similar to that of these previous problems, but considering the changes listed below.

First, all occurrences of the expression $\sum_{\{t \in T | t \leq t\}} l_{j,t}$ in problem (23)-(34) were replaced by $\sum_{\{t \in T | t \leq t\}} \left(\sum_{n \in N} \sum_{p_n \in P_n} a_{p_n}^{j,t} \cdot v_{p_n} \right)$ in problem (71)-(83). This merely means that, while in problem (23)-(34) the target COD is determined by the system planner, in problem (71)-(83) the *contractual COD* will be determined as a result of the auction.

Similarly, the expression $\sum_{j \in J_{DD}} b_j \cdot \left(\sum_{\{t \in T | t \leq t\}} l_{j,t} \right)$ in the objective function of problem (23)-(34) was replaced by $\sum_{\{t \in T | t \leq t\}} \left(\sum_{n \in N} \sum_{p_n \in P_n} b_{p_n}^j \cdot a_{p_n}^{j,t} \cdot v_{p_n} \right)$ in problem (71)-(83). In problem (23)-(34) the “annuity” that is computed to obtain

⁴⁹ Notice that the information of the COD to which the bidder commits to deliver the transmission facility (the *contractual COD*) is given by these parameters. Therefore, the bids include not only the annual revenue requisites, but also the offered *contractual CODs*.

⁵⁰ The reader will notice that the bidder will calculate privately the value of the annual revenue requisites for the package p_n as a whole, but in order to capture the fact that the bidder will only receive the RAP for each specific item of the pack is commissioned after this item is commissioned, we need to have also bids per item. This formulation of the problem allows that the bidder sets different contractual CODs for different items in a package.

the system expansion costs is determined by the system planner and begins to incur in the stage that this planner determines as the target COD. However, in problem (71)-(83) the auctioneer selects package bids p_n that contain both a revenue requisite that will represent the “annuity” used to compute the system expansion costs, and the stage at which this “annuity” will begin to be paid (the contractual COD).

Besides the modified version of the constraints of problem (23)-(34), problem (71)-(83) also contains:

- Constraint (72), which ensures that each item will be allocated to at most one accepted package, functionally similar to a constraint of the combinatorial auction problem of chapter 2 – but with the difference that the *opportunity costs* of not allocating the item to any bidder must not be calculated explicitly as in chapter 2, since these opportunity costs will be reflected directly in the system operation costs computed in the objective function⁵¹;
- Constraint (73), which ensures that at most one package from each bidder will be selected.

6.2 Case study and discussion

6.2.1 Input data

The input data for this case study builds upon that of the case study of section 3.5. Notice, however, that here we: (i) do not consider any uncertainties in implementation times of transmission facilities; and (ii) assume that the CODs to which transmission concessionaires commit as a result of the auction are certain. Analogously to problem (23)-(34), problem (71)-(83) results in a direct choice of the target COD of the transmission facilities.

⁵¹ This happens because, if any of the items is not allocated to any winning package, it will not be *built* in any stage of the problem horizon, and the absence of the transmission facilities will impact system costs.

The five transmission facilities selected as part of the optimal expansion plan obtained as a result of the case study of section 3.5 are assumed to be subject to an auction, in which the bidders compete not only by means of the annual revenues they require to explore the concessions, but also by means at the COD to which they will commit, in their concession contracts, to deliver the facilities (the *contractual COD*).

The auctioneer will evaluate the bids and select winners with help of problem (71)-(83). This means that the optimal solution may include both bids with slightly higher annual revenue requisites, but contractual CODs set to a sooner stage of the horizon, or bids with slightly lower revenue requisites, but contractual CODs set to a later stage of the horizon – the implicit evaluation by means of (71)-(83) will reveal which is the best option. A combinatorial auction protocol is used in this example.

For now, no uncertainties in the actual COD of the projects are considered – i.e., the auctioneer will evaluate the bids assuming that the contractual CODs offered by each bidder will be these in which the company will actually deliver the facilities, if selected as a winner.

We emphasize that the bidders are assumed to reveal their private information about when is their best estimate of the time at which the facility could be delivered. The problem of designing a proper incentive structure to ensure that the agent (transmission company) acts in the interests of the principal (regulator) *is being ignored for now*, though it is precisely the problem expected to be approached in subsequent stages of this doctoral work. Thus, this example aims merely at illustrating the importance of acquiring, during the auction, information on what would be dates at which the competitors believe they would be able to actually deliver the facilities.

We assume that there are 6 bidders participating in the auction, and their bids are characterized as shown in Table 6.1.

Table 6.1. Package bids from each bidder for case study

Bidder	Package	Items in package [-]					Contractual COD offered for each item [stage]					Revenues required per item [1000·\$/4-month interval]				
		j=21	j=22	j=23	j=24	j=25	j=21	j=22	j=23	j=24	j=25	j=21	j=22	j=23	j=24	j=25
1	1	-	Yes	-	Yes	-	-	7	-	10	-	-	21,327	-	17,538	-
1	2	-	Yes	-	Yes	-	-	6	-	9	-	-	22,932	-	18,859	-
2	1	-	-	Yes	-	Yes	-	-	6	-	6	-	-	17,722	-	13,417
2	2	-	Yes	Yes	-	Yes	-	6	6	-	7	-	22,183	17,079	-	12,930
2	3	-	Yes	Yes	-	Yes	-	7	6	-	7	-	21,407	16,481	-	12,477
3	1	-	Yes	-	-	-	-	8	-	-	-	-	21,431	-	-	-
4	1	Yes	-	-	Yes	-	10	-	-	9	-	1,231	-	-	18,458	-
4	2	Yes	-	-	Yes	-	11	-	-	10	-	1,187	-	-	17,812	-
4	3	-	-	-	Yes	-	-	-	-	9	-	-	-	-	19,267	-
5	1	-	-	-	Yes	Yes	-	-	-	9	7	-	-	-	19,079	13,012
5	2	-	-	-	Yes	Yes	-	-	-	10	7	-	-	-	18,678	12,739
6	1	-	Yes	Yes	Yes	-	-	7	6	10	-	-	21,342	15,645	17,333	-
6	2	-	Yes	Yes	Yes	-	-	7	7	10	-	-	21,025	15,413	17,076	-
6	3	Yes	Yes	-	-	-	10	6	-	-	-	1,177	22,439	-	-	-

6.2.2 Results

The following tables show the results of the auction, simulated with help of problem (71)-(83) and the previously described data.

Table 6.2. Case study results: selected package per bidder

Bidder [-]	1	2	3	4	5	6
Selected package per bidder [-]	-	3	-	2	-	-
Items per selected package [-]	-	{22,23,25}	-	{21,24}	-	-

Table 6.3. Case study results: contractual CODs and revenue

Auctioned item [-]	Solution of case study	
	Contractual target COD [-]	Revenue requirements [1000·\$/4-month interval]
21	11	1,187
22	7	21,407
23	6	16,481
24	10	17,812
25	7	12,477

The results are discussed in the next subsection.

6.2.3 Discussion and conclusions

The comparison of the results of the simulated auction (Table 6.3) and the results obtained in section 3.5 reveals that, when the preferences of the transmission companies competing in the auction regarding revenue requirements and contractual CODs are revealed, the schedule of capacity additions to the transmission system can be altered. This emphasizes the importance of acquiring information from these agents during the auctions.

7 APPENDIX B: EXAMPLE OF ESTIMATION OF PROBABILITY DISTRIBUTION OF DELAYS VIA TREATMENT OF HISTORICAL DATA

In chapter 3, we mentioned that the first task required to employ a transmission expansion planning approach that explicitly accounts for uncertainties in implementation times is to estimate probabilities distributions of these implementation times. The planner may do it via several methods, including expert judgment or statistical treatment of historical data.

This Appendix provides a simple example of how statistical treatment may be employed to estimate such probability distributions.

We consider the example of an expansion planner that wishes to estimate the probability distribution for a 500-kV facility including a transmission line spanning through more than 50 km, which will be located in the Northeast of Brazil. The time discretization of the transmission expansion problem our planner will solve refers to semesters.

The planner in this example begins by retrieving the raw historical data on implementation times of transmission facilities located in the Northeast of Brazil. For this, he obtains reports on the monitoring of implementation of transmission facilities issued by the Brazilian regulator between 2014 and 2017 – reference [70] provides an example of one of the reports accessed by the planner – and selects the desired data (already eliminating a few outliers). The planner considers that the set of facilities concluded in period between 2014 and 2017 is sufficiently representative of the challenges that may be faced in the implementation of transmission lines in the near future – but will process the raw data after proceeding to the estimate of the probability distribution of implementation times, as indicated below.

The planner is careful, and first takes the historical data referring to all transmission lines with more than 50 km implemented in the region of interest, also

including facilities at 230 kV. After eliminating outliers, the planner obtains the sample of observations of implementation times that results in the histogram and in the non-parametric estimate of the probability density function⁵² of implementation times depicted below.

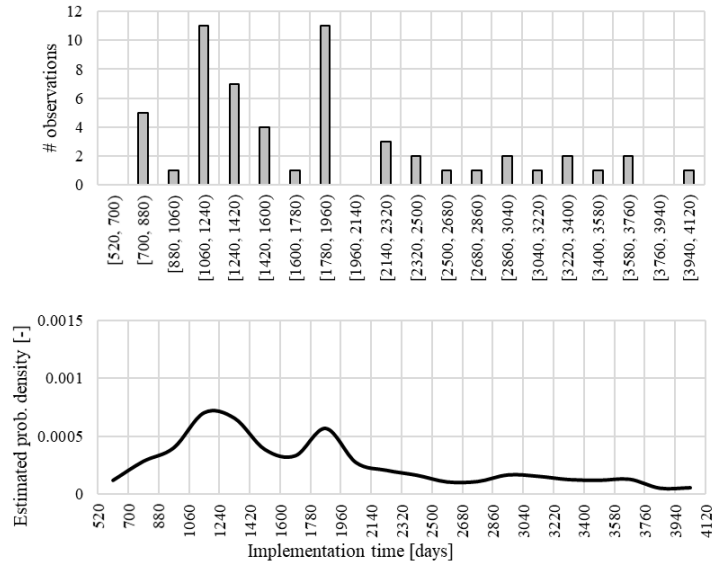

Figure 7.1: Histogram and non-parametric estimate of probability density of implementation times obtained considering historical data referring to 230-kV and 500-kV facilities implemented in the region (Northeast of Brazil) and period (2014-2017) of interest, regardless of the transcos that implemented the facilities

Knowing the problems faced in transmission implementation in the jurisdiction of interest in the recent past, the planner recalls that a specific transco that was very active in the region of interested showed particularly poor implementation performance indicators in the past. To investigate to which extent the performance problems of this specific transco, referred to as *transco X* in the graphs of this section, is affecting the data, the planner divides the data in two sets: a set with the implementation times of facilities for which *transco X* was responsible, and another set with the implementation times of facilities of all other transcos. Knowing that *transco X* is not expected to

⁵² The planner in our example uses kernel density estimation [71] with a Gaussian Kernel, determining the standard deviation of the Gaussian kernel and the bandwidth heuristically.

implement transmission facilities in the near future due to resource limitations, the planner wishes to evaluate whether it should remove the data referring to this transco from the data he will ultimately use for the estimations.

The histograms and non-parametric probability density estimates obtained by the planner are these depicted in Figure 6.2.

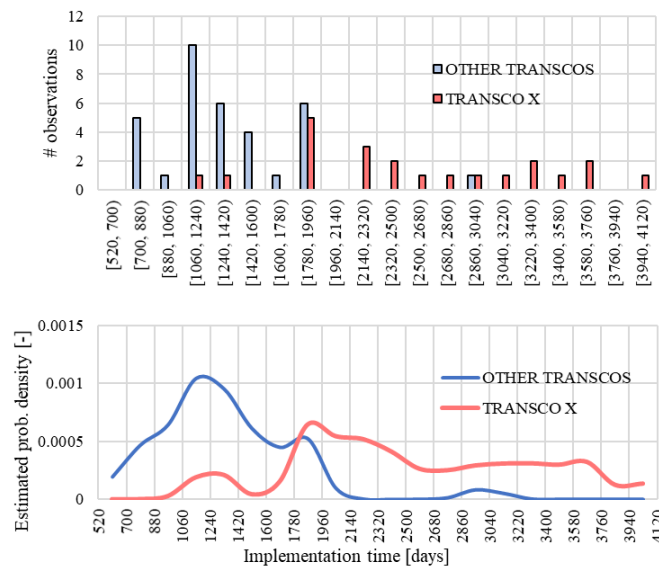

Figure 7.2: Histogram and non-parametric estimate of probability distribution of implementation times obtained considering historical data referring to 230-kV and 500-kV facilities implemented in the region (Northeast of Brazil) and period (2014-2017) of interest: *transco X* (red) and other transcos (blue)

After visual inspection of Figure 6.2, the planner decides to remove the data referring to facilities implemented by *transco X* from the dataset he will use to estimate the probability distributions of interest.

After doing that, the planner now considers only the historical implementation times of 500-kV facilities with more than 50 km for the estimation. He then obtains the histogram and the non-parametric estimate of the probability density function depicted in Figure 6.3.

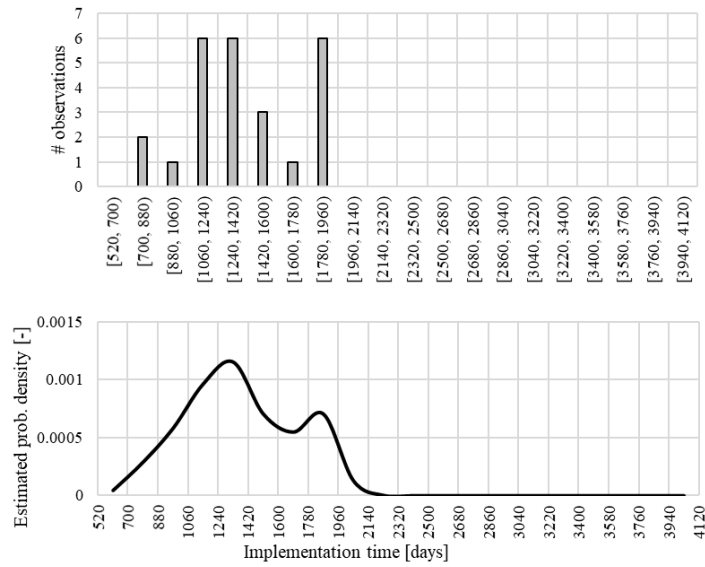

Figure 7.3: Histogram and non-parametric estimate of probability density of implementation times obtained considering historical data referring 500-kV facilities with more than 50 km implemented in the region (Northeast of Brazil) and period (2014-2017) of interest, not including facilities implemented by transco X

The planner in this example is then satisfied with the data at hand. For estimating the discrete probability distributions of implementation times he will use in his planning exercises, the planner can simply integrate the estimated probability function within the intervals of interest – since he will conduct these exercises using semesters as the time discretization, he will integrate the probability density function of Figure 6.3 accordingly.